

# 12/24VDC Carbon Monoxide Detector:

Independently tested to be the only *false-alarm-free* CO detector technology, by a leading authority on indoor air quality\*



## FIREWOLF BY NAPCO

### FW-CO12 12VDC

### FW-CO1224 12/24 VDC selectable

- The first commercially available gas sensor that uses patented biometric technology to simulate CO gas level response in the human blood stream for immunity to false alarms from common household gases
- Independent lab tests prove superior false alarm immunity over electrochemical units (\*Berkeley National Laboratory, report #40566)
- Powerful 85db alarm sounder & LED
- Solid state electronics, won't leak or dry up; not subject to orientation problems of other detectors
- Smart microprocessor and infrared sensor optimize life safety & detection accuracy
- Active self test and LED indicator
- Minimal current draw by incorporating infrared monitoring sensor: 20 ua (microamps) standby. 60mA alarm 30mA trouble
- Form C alarm & trouble relays
- Convenient wall or ceiling mount (includes hardware)
- UL2075 Listed. Tested to meet UL2034 CO response requirement
- Superior long life expectancy of 6 years, backed by an unsurpassed 6 year warranty+

### GENERAL DESCRIPTION

These CO alarms are suited for residences, motels, hotels, and commercial or industrial system applications. The FW-CO12 is designed for 4-6 wire connection to 12VDC alarm system control panels. The FW-CO1224 is designed for 4-6 wire connection to 12 or 24VDC alarm system control panels. Reference: UL Listed Household Fire and/or Burglary Panel with auxiliary signaling zones. Connect to signaling zones which can be designated for CO alarm use only.

### PRODUCT DATA

**Sensitivity Setting:** Unit will alarm at 150 ppm CO within 50 minutes.

**Power:** 12VDC nominal, operating voltage range 10-15 Vdc

**Current Draw:** Standby 20 microAmp. Alarm 60 mA, max. Trouble 30 mA.

**Field Wiring:** 14-22 AWG

Alarm and Trouble Signal Relays Non-Latching

**Contact ratings:** Form "C", 1A - 30Vdc

**Operating Temperature:** 4.4° C - 37.8° C (40° F - 100° F)

**Operating Humidity:** 15-95% RH

**Horn (Sounder) Loudness:** 85 db @ 10 ft(3.3 meters)

4-15/16" diameter x 1-1/2"H (w/ base)

**Compliance:** UL2075 Listed. Tested to meet UL2034 CO response requirement

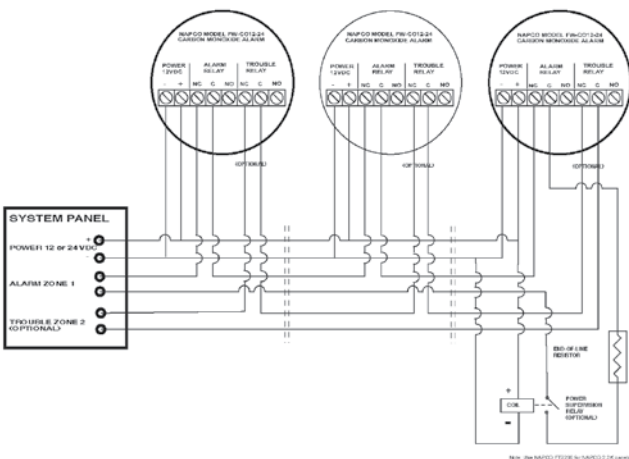

### Wall or ceiling mount

4-15/16" diameter x 1-1/2"H (with base)

333 Bayview Avenue, Amityville, NY 11701 USA

1-800-645-9445 • Fax (631) 789-9292

www.napcosecurity.com

© 2007 NAPCO Firewolf is a trademark of NAPCO 6/07 A561

