

NAPCO SECURITY TECHNOLOGIES, INC.

INTERACTIVE REMOTE SERVICES.
SECURITY TECHNOLOGY SOLUTIONS.

Mobilize more RMR with Napco.

Billable Account Services, Bundle or Standalone



iBridge® Connected Home Services

Control Alarms, Video, Temperature, Lighting & Locking via Z-Wave using iBridge App for iPhone/iPad /Droid or optional award-winning iBridge Touchscreen/Tablet, a 7" portable WiFi full-color tablet with magnetic, on/off wall-mount/charger dock. Cost-effectively add automated Z-Wave Devices with iBridge's affordable bus-mount Z-Wave Module (no touchscreen necessary). Add More with Napco No-Roll™ Customer Service Calls & Service Enhancements, dealers add/edit Z-Wave devices easily, remotely from their own smart devices. Back up all Z-Wave info to the Cloud, too.

(Featured pages 9 to 12)



iRemote™ Virtual Keypad Alarm Control

Works and looks like their real keypad on iPhone/iPad™, Droid™, and smart devices. Anything you can do on a real keypad you can do with Napco App: Arm, Disarm, Bypass, Temp. Control....even service calls from the road. Keypad-bus module for all Gemini, includes 12-mos. subscriber access. No special central station. Retain more accounts enhancing customer experience.

(Featured page 17)



iSee Video™ Remote WiFi Video - The easiest, the first, the best

Hi-Res Streaming Video from easiest 10-minute install WiFi cameras on any smartphone, tablet or PC. Archive and auto-email video of events. All-Inclusive kits with plug-n-play cameras, wireless access point & 12-mos. subscriber service on dealer-customized site.. No account activation fee. Exclusive 24/7 Recording option.

(Featured pages 13 to 16)



StarLink GSM Series Universal Future-Proof Radios & App

Starting under \$100, two advanced primary/backup radio works on any panel* anywhere for full reporting to any Central. No activation fee. Two Future-Proof Field-Upgradable Models: Original SLE-GSM Radio and SLE-GSM-3/4G, New 3G/4G Network-Ready Version. Includes Takeover-Feature, SMS text option; 1-Step Enrollment; GEM-Panel up/downloads & Customer Remote Arm/Disarm App for iPhone, iPad & Droid. *Panel must report Contact ID/4/2.

(Featured on page 20)



FLEXIBILITY: To Go Anywhere.



FIRE:
**FIREWOLF 24V ADDRESSABLE,
CONVENTIONAL & WIRELESS FIRE**

Up to 255 intelligent points from widest line 24V, 12V & UL Commercial Wireless input/output devices. More power: 7A onboard & 4 programmable NACs (up to 24); 32Ah backup. Quick AHJ/ Smoke Obscuration reports. Built in Horn/Strobe Sync, Dual DACT, TCP/IP option. Longest runs, all wire types, ideal for 12V/ legacy retrofits; over 10,000' of SLC cable.

New! Fire Quick-Start System Programming & EZ-Maintenance Modes.

INTRUSION:
**GEMINI COMMERCIAL ADDRESSABLE
BURGLARY**

Gemini Commercial Addressable/Conventional 96-Point Burglary System. Supports full line of GEMC Commercial-rated wireless, conventional and addressable devices simultaneously - scalable from 8 to 96 points, with up to 7 partitions.

COMBINATION:
**GEMINI COMMERCIAL COMBINATION
24V/12V FIRE & BURGLARY &/OR ACCESS**

Scalable 32 to 255 Points of addressable, conventional and/or commercial wireless. UL 864, 9th Edition - Preisolated Fire & Burg. busses, separate generous power supplies & separate service loops. Built in Dual DACT (internet option). Option for add-on access control. Familiar Napco software and Gemini style, menu-driven keypads. Powerful battery capacity up to 32Ah total (fits within housing).

Flexibility for Every Application:

- ✓ Scalable, 32 to 255 points
- ✓ More value out-of-the-box - Saves substantial equipment costs
- ✓ Easy to use, menu-driven keypads: also keyswitch and fire city tie module options.
- ✓ Wide array of commercial-rated devices, addressable, wireless & conventional
- ✓ Merchantile, flush or surface mount panels

Value & Power-Packed

- ✓ 4 onboard programmable NACs, expands to 24; 7 Amps onboard power
- ✓ Built in Horn/Strobe Sync & Dual DACT. TCP/IP available
- ✓ AHJ reports, local or remote printing
- ✓ 3-Year Napco Panel Warranty

**Many Systems from One Flexible Napco
Napco Commercial Platform**

- ✓ Intelligent Addressable Fire, with true 24V operation
- ✓ Conventional Fire/Addressable Fire simultaneously - for retrofit & new installs
- ✓ Conventional Fire Waterflow
- ✓ Commercial Wireless Fire or Wireless Burglary
- ✓ Award-Winning Combo. 24V Fire/Burg
- ✓ Addressable Intrusion (only)
- ✓ Integrated Access Control option

**Free 8 ceu, factory-certification classes
in the field & online - Register at
www.napcosecurity.com/training**



Napco Commercial™ GEMC Combo. Fire/Burglary and



GEMC-COMBO255KT 255 Point GEM-C Commercial Combo. Fire/Burg System Kit

- 24V Panel, 255 Points via commercial addressable, wireless or conventional fire or burg. devices, 4 on board NACs, 8 partitions (No Loop Isolator/Extender required)
 - 7 Amp, 24V Power Supply
- Burg. Module, with power supply with built in bus isolator for complete separation of fire and burg power and battery standby operation (GEMC-BM/PS)
- Built in horn/strobe synch. module on each NAC (Wheelock & System Sensor protocol)
- Built in dual line communicator; dual onboard serial ports
- Quickloader up/downloading including remote smoke obscuration reporting
- Locking, Large Red Enclosure, 16 x 25" reversible door, with 14.25" x 25" base (flush or surface mount.) Houses up to 32Ah battery backup.
- Menu-driven LCD Fire Keypad (GEMC-FK1) mounts anywhere on bus (Also, full keyswitch support)



GEMC-COMBO128KT 128 Point GEM-C Commercial Combo. Fire/Burg System Kit

- 24V Panel, 128 Points via commercial addressable, wireless or conventional fire or burg. devices, 4 on board NACs, 8 partitions (No Loop Isolator/Extender required)
 - 7 Amp, 24V Power Supply
- Burg. Module, with power supply with built in bus isolator for complete separation of fire and burg power and battery standby operation (GEMC-BM/PS)
- Built in horn/strobe synch. module on each NAC (Wheelock & System Sensor protocol)
- Built in dual line communicator; dual onboard serial ports
- Quickloader up/downloading including remote smoke obscuration reporting
- Locking, Large Red Enclosure, 16 x 25" reversible door, with 14.25" x 25" base (flush or surface mount.). Houses up to 32Ah battery backup.
- Menu-driven LCD Fire Keypad(GEMC-FK1) mounts anywhere on bus (Also, full keyswitch support)



GEMC-COMBO32KT 32 Point GEM-C Commercial Combo. Fire/Burg System Kit

- 24V Panel, 32 Points via commercial addressable, wireless or conventional fire or burg. devices, 2 on board NACs, 8 partitions (No Loop Isolator/Extender required)
 - 7 Amp, 24V Power Supply
- Burg. Module, with power supply with built in bus isolator for complete separation of fire and burg power and battery standby operation (GEMC-BM/PS)
- Built in horn/strobe synch. module on each NAC (Wheelock & System Sensor protocol)
- Built in dual line communicator; dual onboard serial ports
- Quickloader up/downloading including remote smoke obscuration reporting
- Locking, Large Red Enclosure, 16 x 25" reversible door, with 14.25" x 25" base (flush or surface mount.). Houses up to 32Ah battery backup.
- Menu-driven LCD Fire Keypad (GEMC-FK1) mounts anywhere on bus (Also, full keyswitch support)



Napco Commercial GEMC Burglary (Only) GEMC-BURG96KT 96pt GEMC Addressable Commercial Burglary System Kit

- 24V Panel, 96 Points via commercial addressable, wireless or conventional burg. devices, 7 partitions
- Locking, Medium White Enclosure, 16 x 17" door, with 14.25" x 16" base (flush or surface mount.). Houses up to 16Ah battery backup.
- 4 Amp, 24V Power Supply
- Addressable SLC Burg Module, supports up to 96 addressable SLC burg devices (GEMC-BSLC)

- Built in dual line communicator; dual onboard serial ports
- Quickloader up/downloading
- Menu-driven LCD Burglary Keypad with built-in 4 zone EZM, mounts anywhere on bus (GEMC-BK1)

7Amp NAC Extender for Universal FACP use or with GEMC Systems

GEMC-NAC7S

- 7 Amps of Power for use with NAPCO or other FACP panel brands
- 4 onboard NACs with up to 2A ea. expandable for up to 24 per system
- Regulates 24V auxiliary power
- Distributes synched bell and strobe outputs with built-in module
- Monitors AC, battery trouble, tamper and ground fault on Napco bus or provides universal FACP support
- Red locking enclosure, accommodates up to 16Ah total battery capacity



12VDC Burglary Power Supply for GEMC and Gemini Panels GEMC-12V2PS-R 12VDC

- Power Supply for Burg. Bus of GEMC Panels, remote supervised.
- Powered by supplied 16.5V, 50VA plug-in transformer,
- Supports 2ea. 12V, 7Ah standby batteries.
- Backward compatible with all standard Gemini Panels, too.
- Alarm Panel supervised power option



(Note: Housing is white in color, not as shown.)

Note: Also available, Fire Bus Model with Direct 120VAC connection, model GEMC-12V2ASP-CF 12VDC

Napco Commercial Access Control Option for GEMC and Gemini Panels

- **GEMC-ACM1D** Access Control Module with power supply in enclosure
- **GEM-2D** 2nd Door Plug-In Module for use with ACM1D

Burglary & Fire Accessories & Options:

Wireless, UL Commercial, Peripherals

- **GEMC-REVC** Wireless 255 point RF Receiver (4/system, max.)
- **GEMC-WL-SMK** Wireless Smoke, Photoelectric
- **GEMC-WL-HEAT** Wireless Heat, 135° F



- **GEMC-WL-WD** Wireless 1-pt input module
- **GEMC-WL-WD2** Wireless 2-input module
- **GEMC-WL-PIR** Wireless 50' PIR
- **GEMC-WL-DT** Wireless 40' Dual Tech'y microwave/PIR
- **GEMC-WL-GB** Wireless Glassbreak

Burglary Configurations and Components:

Commercial Fire & Burglary Accessories and Options

GEMC-BM/PS Burg Module with 12V power supply provides isolated 4-wire burg bus for burg keypads and devices, plus 12V power output for aux. devices. Independent Burg. Bell output. Complete separation of fire and burg power, plus indep. burg. battery connection and charger for indep. burg. standby operation in power failure.

GEMC-BM Burg Module, isolated 4-wire burg bus for burg keypads and devices, plus 12V power output for aux devices. Indep. Burg bell output.

GEMC-FW-SLC Addressable SLC Fire Module, supports up to 128 addressable SLC fire devices. Up to 2 connect to GEM-C panel.

GEMC-BSLC Addressable SLC Burg Module, supports up to 128 addressable SLC burg devices. Up to 2 connect to GEM-C panel.

GEMC-F8ZCPIM Conventional 8-zone 2-wire fire input module. Plugs into GEM-C panel, for conventional 2-wire smokes or any conventional fire detection device.

Burglary Peripherals

GEMC-BK1 LCD Burglary Keypad for Combo. System, with 4-zone EZM built in (Requires GEMC-BM or BM/PS Module.)

GEMC-BSLC-4PT Addressable SLC 4 point input expansion module

GEMC-BSLC-1PT Addressable SLC 1 point input expansion module

GEMC-BSLC-DT Addressable SLC Commercial Dual Tech Microwave/PIR, 40 x 40'

GEMC-BSLC-PIR Addressable SLC Commercial PIR, 50 x 50'

GEMC-BSLC-RLY Addressable SLC Commercial 1 point output module

GEMC-WL-PIR Gemini Commercial Wireless PIR, 50 x 50'

GEMC-WL-GB Gemini Commercial Wireless Glassbreak, Acoustic 25'

GEMC-WL-DT Gemini Commercial Wireless Dual Tech Microwave/PIR, 40 x 40'

Fire Peripherals

GEMC-FK1 LCD Fire Red Keypad

GEMC-WL-SMK Gemini Commercial Wireless Smoke, Photoelectric

GEMC-WL-HEAT Gemini Commercial Wireless Heat, 135° F

Common Peripherals - For Commercial Fire and/or Burglary Systems

GEMC-WL-WD Gemini Comm Wireless slim profile 1-input wireless module

GEMC-WL-WD2 Gemini Comm Wireless 2-input module converts any UL listed device into a UL wireless device (ex., pull stations or sprinkler supervisories.)

GEMC-REVC Gemini Commercial Wireless 255 point RF Receiver (up to 4 per system, max.)

GEMC-EZM8 8-point expansion module

GEMC-FPRINT Parallel printer module

GEMC-RM3008 8 Form C Relay Output Module

GEMC-NL-MOD Internet Reporting Module

GEMC-RS232 RS232 Adapter for serial output from GEMC Panel

GEMC-OUT8 PGM Output Module, 8 open collector PGM outputs

GEMC-KOTamperKT Merchantile Tamper Kit, for large panel enclosures, supervised. (Not necessary if housing is recess-mounted.)

Firewolf Addressable Peripherals

FWC-FSLC-SMK Addressable Analog SLC Smoke, photoelectric, head**

FWC-FSLC-HEAT Addressable Analog SLC Heat, 135°F, head**

FWC-FSLC-DUCT Addressable SLC Duct smoke detector, photoelectric

FWC-FSLC-DUCTRA Remote Indicator Plate with LED indicator & key reset.

FWC-FSLC-EZM2 Addressable SLC 2-zone conventional expansion module. Uses one address on SLC loop, but yields 2 indep contact monitoring circuits, for pull stations, water flow and other dry contact alarm initiating devices.

FWC-FSLC-EZM1 Addressable SLC 1-input conventional module, similar to usage above.

FWC-FSLC-CZM Addressable SLC single module, for monitoring of dry contacts, ie., pull stations and conv. smokes

FWC-FSLC-RM2 Addressable SLC 2-output module (requires 1 SLC address)

FWC-FSLC-ISO Addressable SLC Short Circuit Module. (Optional use, for certain apps. only; meets Class A, Style 7 loop reqts.)

FWC-FSLC-SOM1 Addressable SLC Fire supervised output module. Application examples: elevator recall, HVAC shutdown, add'l NAC output with power supply

FWC-FSLC-PULL Addressable SLC Fire Pull Station

FWC-FSLC-PULLK Addressable SLC Pull Station, key reset

FWC-FSLC-PULL2 Addressable Dual Action Pull Station

FWC-FSLC-PULL2K Addressable Dual Action Pull Station, Key Reset

FWC-FSLC-PROG2 Tool for address-programming SLC devices

FWC-FSLC-SMK6B ** Smoke/Heat 6" Base, required for FWC-FSLC-SMK and -HEAT devices

Options

GEMC-12V2APS-CF 12VDC Power Supply for Fire Bus, remote supervised. Direct 120VAC connection, supports 2ea. 12V, 7Ah standby batteries.

GEMC-12V2APS-R 12VDC Power Supply for Burg. Bus, remote supervised. Powered by supplied 16.5V, 50VA plug-in transformer, supports 2ea. 12V, 7AH standby batteries.

GEMC-NAC6 Remote 4-output NAC Extender, for 6.5A ttl, or 2A, max. on any 1 output. Red 14 x 16" can, connects to 120VAC, supports 32Ah standby batts. Supervised, fire bus connection. System Sensor and Wheelock NAC synch. (5 per system, for 20 add'l NAC circuits total.)

GEM-ACM1D Access Control Module (with power supply, provision for back up battery, in enclosure, plug-in transformer), 1 door kit

GEM-2D Access Add-on 2 door plug-in PCB for expansion of door capacity in above.

Napco Commercial Platform: GEMC Fire & Burglary



Platform supports commercial, addressable, wireless or conventional fire or burglary devices.

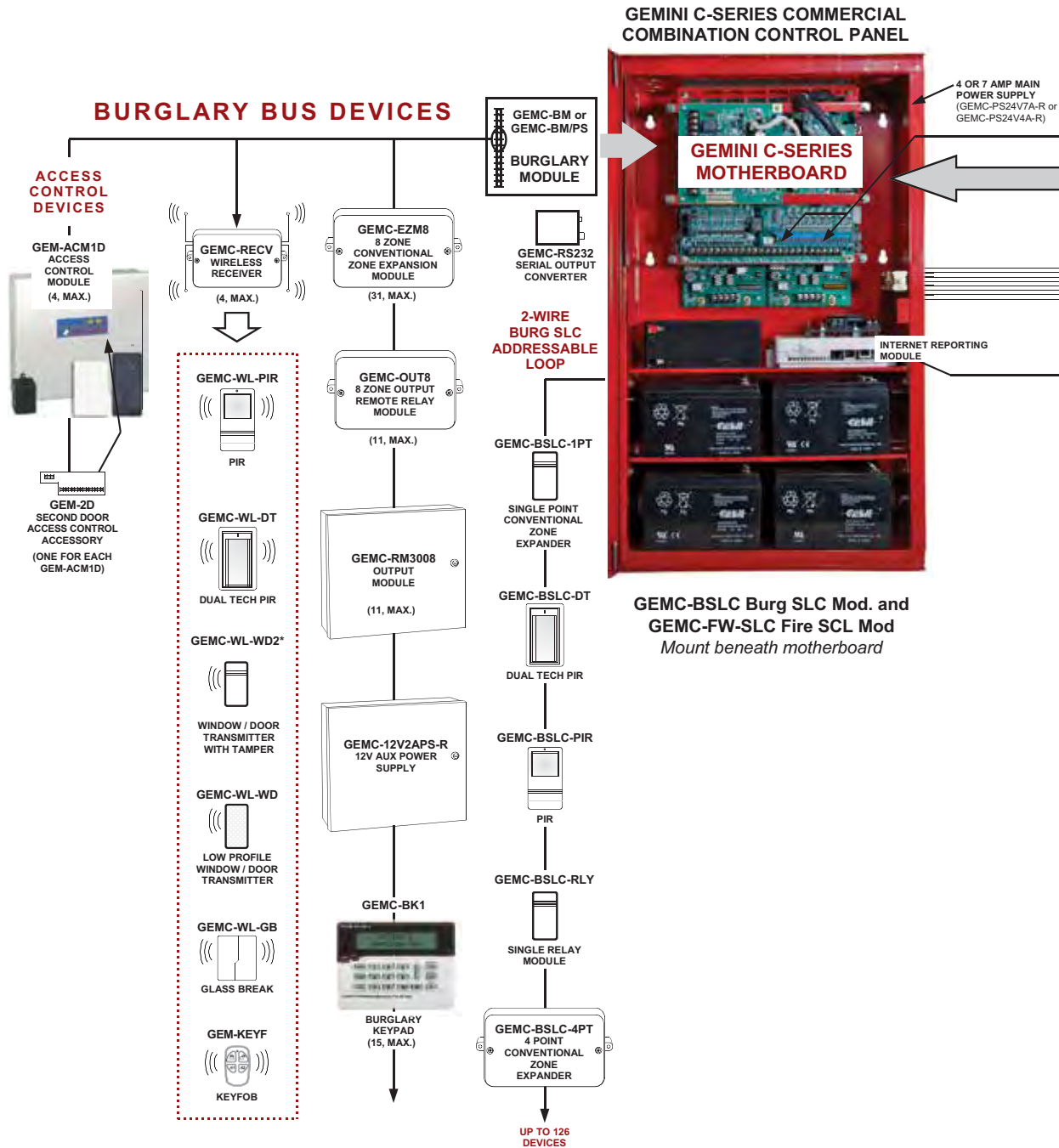

2 SLC MODULES, max.

- Two Fire or
- Two Burglary or
- One Fire and one Burglary

Note: The four GEMC-RECV max. is reduced by 1 for each SLC module.

†Residential Burglary when both loops are used
Single Commercial Burglary Supervised Loop and Integral Magnetic Contact

Configuration Diagram

FIRE BUS DEVICES

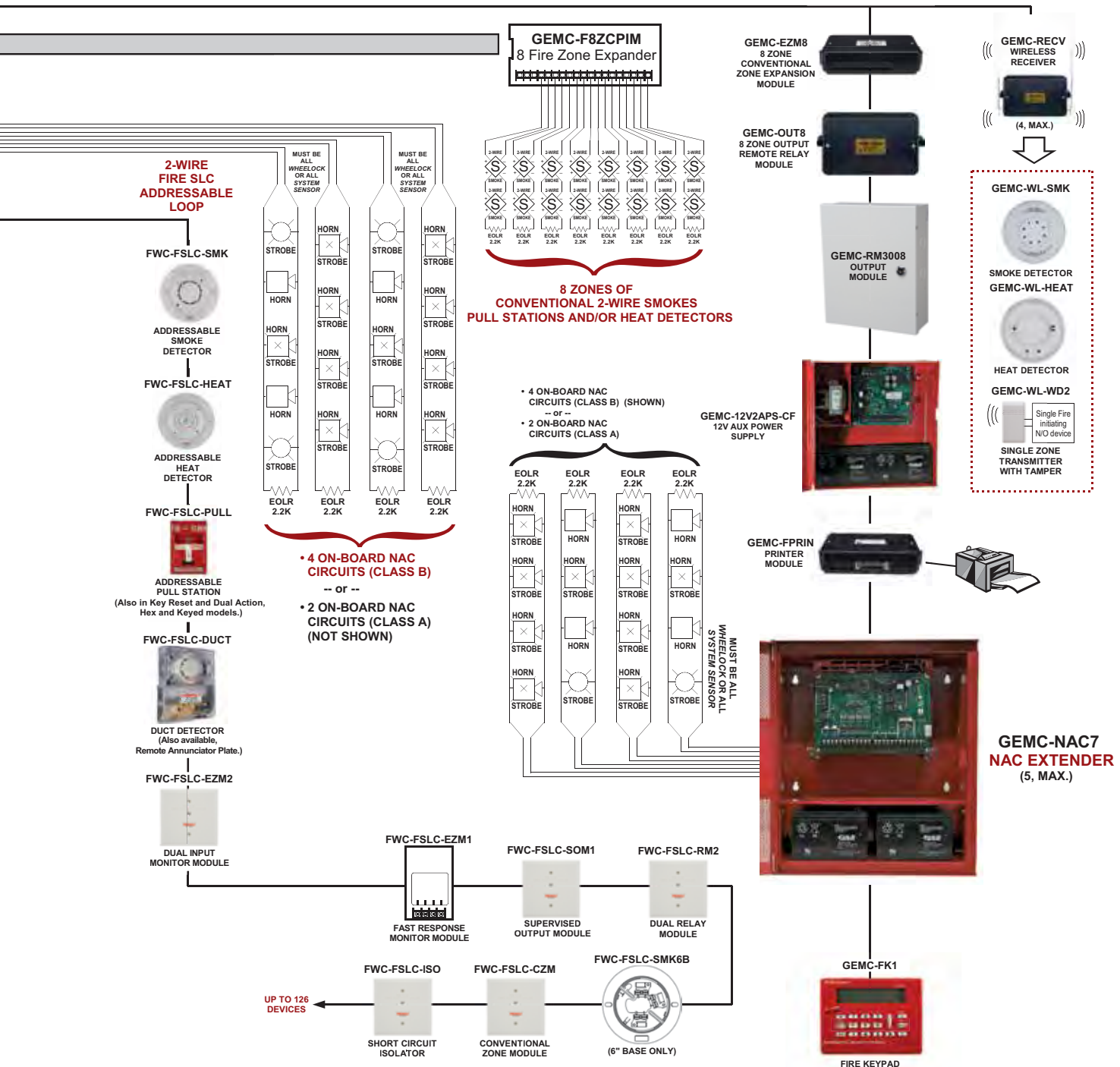

Firewolf™ Series Addressable 24V Fire Systems up to 255 intelligent points:

Firewolf™ Series Intelligent features, cost-effective design and up-to-the-minute, compliance

Features:

- ✓ Analog, Addressable, Conventional, Wireless &/or Hardwired technologies
- ✓ Wireless Fire - Full line of UL Commercial Grade long-range supervised models
- ✓ More Addressable Devices than any in its class; mile-long loop lengths and more device load ea. ch. Supports 10,000 Feet of SLC Cable!
- ✓ **New & Improved! Fire Quick-Start System Programming & EZ-Maintenance Modes**
- ✓ More value and power on-board for a more cost-effective solution -
 - Built in DACT (TCP/IP option), Horn/Strobe Sync. (Wheelock/System Sensor protocol), 4 programmable NACs (up to 24), 7A power, regulated 24V output
- ✓ Cost-effective retrofits - supports conventional legacy devices & existing wiring (all types/gauges)
- ✓ Comprehensive local and remote programming & diagnostics.
- ✓ Quick Smoke Obscuration Reports for AHJs (Printable reports of analog device sensitivity settings with current readings (uploadable))
- ✓ Optional NAC Extender for universal FACP support and Regulated Power Supplies, too
- ✓ Code-compliant integrated Security System option with independent pre-isolated circuits
- ✓ **Compliances** - NFPA 72, UL Commercial Fire, UL864 9th Ed., UL985, CSFM and NYCFD.



Napco Commercial Firewolf™ Fire System Kit Configurations:

Napco Commercial Firewolf 255pt 24V Intelligent Addressable Commercial Fire System Kit GEMC-FW-255KT



- 24V Panel, 255 pts via commercial addressable, wireless or conventional fire devices, 4 on onboard v NACs providing up to 6.5A notification power
- 7Amp, 24V Power Supply
- Built in horn strobe sync on each NAC (Wheelock/System Sensor protocol)
- Built in dual line communicator; dual onboard serial ports; optional TCP/IP
- **New Fire Quick-Start System Programming & EZ-Maintenance Modes;** Quickloader up/downloading incldg Quick access, Smoke Obscuration Reports, Automatic drift compensation for smoke detectors too
- Nearly a mile max. wiring run - any wire type - ideal for retrofits. 24V and 12V legacy devices supported
- Large red locking enclosure, flush or surface mount. Up to 32AH battery capacity.
- Includes Fire Keypad (GEMC-FK1) LCD display, menu-driven, mounts anywhere on bus. (Also global keypad unlock feature & full keyswitch support.)

Napco Commercial Firewolf 128pt 24V Intelligent Addressable Commercial Fire System Kit GEMC-FW-128KT



- 24V Panel, 128 pts via commercial addressable, wireless or conventional fire devices, 4 on onboard programmable NACs providing up to 6.5A notification power.
- 7Amp, 24V Power Supply
- Built in horn strobe sync on ea. NAC
- Built in dual line communicator; dual onboard serial ports; optional TCP/IP
- **New Fire Quick-Start System Programming & EZ-Maintenance Modes;** Quickloader up/downloading including Quick access, Smoke Obscuration Reports; Automatic drift compensation for smoke detectors too
- Nearly a mile max. wiring run - any wire type - ideal for retrofits.
- Supports 24V and legacy 12V devices
- Large red locking enclosure, flush or surface mount. Up to 32AH battery capacity
- Includes Fire Keypad (GEMC-FK1) LCD display, menu-driven, mounts anywhere on bus (Also, global keypad unlock feature & full keyswitch support.)



Napco Commercial Firewolf 32pt 24V Intelligent Addressable Commercial Fire System Kit GEMC-FW-32KT

- 24V Panel, 32 pts via commercial addressable, wireless or conventional fire devices, 2 on onboard NACs providing up to 4A notification power.
- Locking medium red enclosure (flush or surface mount). Houses up to 16AH battery backup.
- 7Amp, 24V Power Supply
- Built in horn strobe synch module on ea. programmable NAC
- Built in dual line communicator; dual onboard serial ports; optional TCP/IP
- **New Fire Quick-Start System Programming & EZ-Maintenance Modes;** Quickloader up/downloading incldg Quick access, Smoke Obscuration Reports, Automatic drift compensation for smoke detectors too
- Nearly a mile max. wiring run - any wire type - ideal for retrofits. 24V and 12V legacy devices supported.
- Includes Fire Keypad (GEMC-FK1) LCD display, menu-driven, mounts anywhere on bus (Also, full keyswitch support.)



Napco Commercial Firewolf 32pt Conventional Fire System Kit - Ideal for sprinkler/waterflow GEMC-FW-32KT GEMC-FW32CONVKT

- 24V Panel, 32 Points via commercial addressable, wireless or conventional fire devices, 2 onboard programmable NACs providing up to 4A notification power
- Locking, Medium Red Enclosure, 16 x 17" door, with 14.25" x 16" base (flush or surface mount). Houses up to 16Ah battery backup.
- 4 Amp, 24V Power Supply
- Conventional 8-zone 2-wire fire input module, for conventional 2-wire smokes or any conventional fire detection device (GEMC-F8ZCPIM)
- Built in horn/strobe synch. module on each NAC (Wheelock/System Sensor protocol)
- Built in dual line communicator; dual onboard serial ports
- **New Fire Quick-Start System Programming & EZ-Maintenance Modes;** Quickloader up/downloading
- Menu-driven LCD Fire Keypad mounts anywhere on bus (GEMC-FK1)

7Amp NAC Extender for Universal FACP use or with GEMC / Firewolf Systems GEMC-NAC7S



- 7 Amps of Power for use with NAPCO or other FACP panel brands
- 4 onboard programmable NACs with up to 2A ea. expandable up to 24 per system
- Regulates 24V auxiliary power
- Distributes synched bell and strobe outputs with built-in module
- Monitors AC, battery trouble, tamper and ground fault on Napco bus or provides universal FACP support
- Red locking enclosure, accommodates up to 16Ah total battery capacity

12VDC Fire Power Supply for GEMC / Firewolf and Gemini Panels GEMC-12V2ASP-CF 12VDC



- Power Supply for Fire Bus of Firewolf & GEMC Napco Commercial Panels, remote supervised
- Direct 120VAC connection
- Supports 2ea. 12V,7Ah standby batteries

Wireless, UL Commercial, Fire Peripherals

GEMC-REVC Wireless 255 point RF Receiver (4/system, max.)

GEMC-WL-SMK Wireless Smoke, Photoelectric (complete)

GEMC-WL-HEAT Wireless Heat, 135° F

GEMC-WL-WD Wireless 1-pt input module

GEMC-WL-WD2 Wireless 2-input module (converts any UL device into a wireless device, ex. pull stations or sprinkler supervisors.)



FIREWOLF FIRE SYSTEMS & COMPONENTS

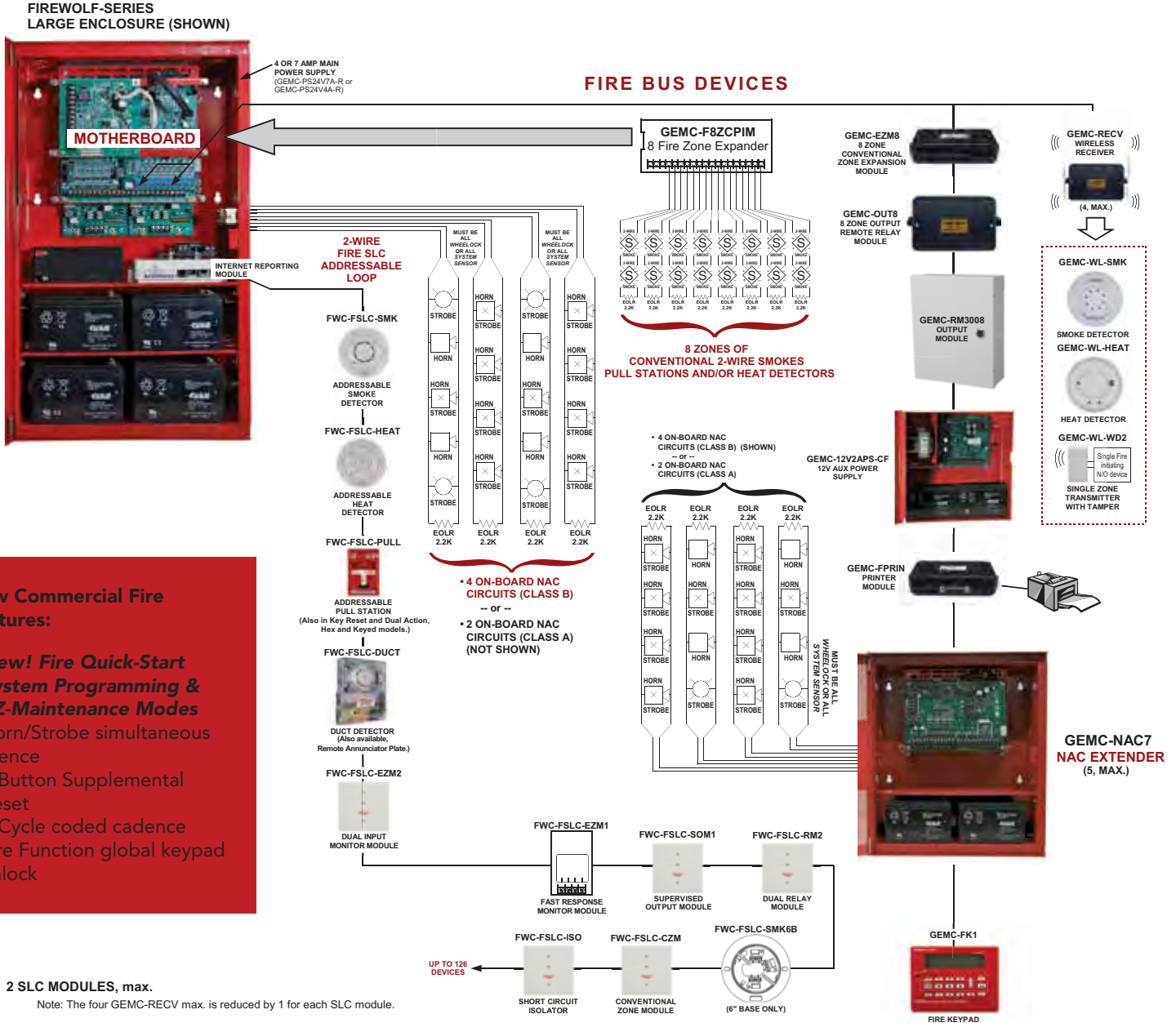

New Commercial Fire Features:

- **New! Fire Quick-Start System Programming & EZ-Maintenance Modes**
- Horn/Strobe simultaneous silence
- 1-Button Supplemental Reset
- 4-Cycle coded cadence
- Fire Function global keypad unlock

Addressable Fire Peripherals

- GEMC-FW-SLC** Addressable SLC Fire Module, supports up to 128 addressable SLC fire devices, below. (Connect up to 2/panel.)
- FWC-FSLC-SMK** Addressable Analog Smoke Photoelectric, head**
- FWC-FSLC-HEAT** Addressable Analog Heat, 135 degrees, head**
- FWC-FSLC-DUCT** Addressable Duct smoke detector, photoelectric.
- FWC-FSLC-DUCTRA** Remote Indicator Plate with LED indicator & key reset
- FWC-FSLC-EZM1** Addressable SLC 1-input conventional module, similar usage to above.
- FWC-FSLC-EZM2** Addressable 2-zone conventional expansion module. Uses one address on SLC loop, but yields 2 independent contact monitoring circuits for pull stations, waterflow and other dry contact alarm initiating devices.
- FWC-FSLC-CZM** Addressable single module, for dry contacts
- FWC-FSLC-RM2** Addressable 2-output module (uses 1 SLC address)
- FWC-FSLC-ISO** Addressable Short Circuit module (Optional for special apps., meets Class A, Style 7 loop reqts.)
- FWC-FSLC-SOM1** Addressable Fire supervised output module (ex. Elevator recall, HVAC shutdown, additional)
- FWC-FSLC-PULL** Addressable Pull Station
- FWC-FSLC-PULLK** Addressable Pull Station, Key Reset
- FWC-FSLC-PULL2** Addressable Dual Action Pull Station

- FWC-FSLC-PULL2K** Addressable Dual Action Pull Station, Key Reset
- FWC-FSLC-PROG2** Tool for address programming SLC devices
- FWC-FSLC-SMK6B** **Smoke/Heat, 6" base required for FWC-FSLC-SMK & -HEAT

Conventional Fire Peripherals

- GEMC-FK1 LCD** Fire Red Keypad (Menu-driven operation, functionality for Reset, Acknowledge, Silence (with disable).
- GEMC-F8ZCPIM** Conventional 8-zone 2-wire fire input mod.
- GEMC-EZM8** 8-pt expander
- GEMC-NL-MOD** Internet Reporting Module

Output Options for Fire Systems

- GEMC-FPRINT** Parallel printer module
- GEMC-RM3008** 8 Form C Relay Output Mod
- GEMC-RS232** RS232 Adapter for serial output
- GEMC-OUT8** PGM 8-Output Module

New Options:

- FN-CTM** City Tie Module Option
- GEMC-KEYSWKT** Keyswitch Kit
- GEMC-LOCK-CAT30** Keyed-Alike pull stations & panel enclosures

Firewolf Conventional Fire/ Lifesafety Devices



Advanced photoelectric smoke detectors

Proven to more accurately detect a wide range of fire types and to reliably, outperform conventional photoelectric detectors. Detects virtually all types of fires including paper, wood, gasoline, polystyrene, and smoldering fires.

FW-2 2-Wire

FW-4 4-Wire

- Low Profile
- RF/Transient Protection
- Two built-in power/sensitivity/supervision/alarm LEDs
- Non-directional smoke chamber
- Vandal resistant security locking feature
- Removable smoke labyrinth for cleaning or replacement

FW2H Also available with Heat Sensor

- With built-in thermal heat sensor for more fire codes requiring 135°F fixed



More sound in fire...

Firewolf 2-Wire Smoke Detectors with built-in 85db sounder and Line Reversal Module

FW2S Smoke Detector with built-in sounder

FW-RM1 Reversal Module



Advanced photoelectric smoke with built-in thermal heat detector

FW2-H 2-Wire with heat, **FW4-H** 4-Wire with heat

Same features as FW-2 & FW-4 plus -

- Built-in thermal heat sensor for more fire codes requiring 135°F fixed.



Firewolf 12/24VDC carbon monoxide detectors

FW-CO12 12VDC

FW-CO1224 12/24VDC (selectable)

- Designed for professional residential & commercial alarm systems
- UL2075 Listed. Tested to meet UL2034 CO response requirement
- 12 to 24VDC for varied applications
- Attractive compact styling (under 5") and neutral color for every décor
- Precise solid state infrared sensor technology & smart microprocessor optimize life safety & detection accuracy
- Patented technology: Simulates CO gas level response in human blood stream
- Independent lab tests prove superior false alarm immunity over electrochemical units (Lawrence Berkeley National Laboratory #40566)
- Powerful 85db alarm sounder & LED
- Easy Test/ Silence-Reset button



Conventional single action, dual action & key-reset pull stations

FW-PULL1

- Non-coded single or double action devices which initiate an alarm when pulled.
- Resetting of the FW-PULL1 is accomplished by inserting a small screwdriver
- Durable extruded aluminum construction and finished in red
- Pull stations can be converted to dual action with the addition of the FW-PULL2MOD double action lever kit
- Key reset version also available **FW-PULL1K**

iBridge Remote Services & Apps:

Grow your business & RMR in any economy (and prevent attrition)



iRemote™ Virtual Keypad Module & App – Anything you can do on a real on-premises keypad you can do remotely, even service calls

- Arm/Disarm
- Bypass, Temp. Control
- Address Programming – For gas-free updates/service calls
- Works the same/ looks the same – nothing new to learn/teach – control anywhere there's internet access
- Free App on smart device, tablet or PC.
- Dealer-Customized Subscriber Access Site included, Multilingual
- No special central station required

iRemote



iBridge® Connected Home Services - App & Optional Touchscreen/Tablet

- Control Alarms, Video, Temperature, Lighting & Locking
- Turn on/off lights and alarms; lock/unlock doors; set thermostats or set moods or scenes; view local & remote video, get emailed videos.
- Cost-Effective Z-Wave Device Control just using iBridge's affordable bus-mount Z-Wave Module.
- Activate custom scenes based on, schedules or occupancy from tablet or phone
- Napco No-Roll™ Customer Service Calls - Dealers Edit / Add Z-Wave devices easily, remote-configurable from their own smart devices.
- Bridge App for iPhone/Droid or PC &/or WiFi Touchscreen/Tablet



iSee Video™ Remote Video – The Easiest, The First, The Best

- Hi-Res Streaming Video - 25FPS @ VGA res. 640x480
- 10-Minute WiFi Camera Installation – No Activation Fees; All-inclusive kits w/ 12-mos. Service
- Plug-n-Play Easy Camera Enrollment; Secure WiFi Network
- View Live, Archived or Auto-Email on Events; viewable anywhere there's internet access
- Detail /Quality you can see and zoom-in on!
- 24/7 Recording Option
- Dealer-Customized Subscriber Access Site included, Multilingual
- Free Sales Aids

iSeeVideo



StarLink GSM Universal Radio & App

- Starting at under \$100, advanced primary/ backup full data radio works on any panel (Contact ID/4/2), anywhere
- Free App: One-touch remote arm/disarm for customer convenience from anywhere (with status indicator); SMS text/email option
- Programmed out-of-the-box, with 1-step enrollment. No activation fee.
- Takeover Feature to change CS (reports to any)
- Future-Proof, field upgradable for network changes
- Optional – Gemini Panel up/downloads in minutes
- Free Sales Aids



iBridge® Connected Home Services App & Optional Touchscreen/



iBridge Connected Home App

iBridge®

iBridge on the go

Z-Wave Automation



iBridge App for Smart Phones/Devices /Tablets or PC controls all. (Available on iTunes or Google Play.)



iBridge® Connected Home Services App for Smartphones & services added to any Gemini Security System. Affordable,

Control Alarm, Video, Temperature, Lighting & Locking via iBridge & Z-Wave: iBridge App for iPhone/iPad/Droid &/or Award-Winning 7" full-color WiFi Touchscreen/Tablet provides RMR-building services your customers will Love - Turn on/off lights and alarms; lock/unlock doors; set thermostats or set moods or, scenes or schedules; view local and remote video; get email alerts & video clips on smart devices, PC or touchscreen.

iBridge Automated Z-Wave™ Device Home Controls, More Convenient for Accounts & Dealers by Design: iBridge home controls, including indoor and outdoor lights, dimmers, thermostats, locks and small appliances, operate using Z-Wave, a proven, wireless mesh networking technology that is a standard in wireless home control. Devices can be manually activated, locally or remotely, and set to respond with custom scenes, schedules or occupancy, ie, when a room is entered lights light, temperature is increased, etc.(even when the system is disarmed.) Anytime a custom scene is created a button with the same name is automatically added to the Scenes screen, so that it can be manually activated, as well as scheduled, too. (see Scene Control on iPhone, above, center.)

Z-Wave Device Control from iBridge's more economical bus-mount Z-Wave Module IBR-ZREMOTEMOD (shown at right). Uniquely, and more cost-effectively, with Napco, it's not necessary to have a touchscreen on the system for home control automation , all it takes is this module, that mounts right on the keypad bus and can be used with all Gemini Panels and an array of standard Z-Wave devices. (See configuration diagram next page). Get double the Z-Wave range with Napco's superior antenna pattern!



Napco No-Roll™ Customer Service Calls & Service Enhancements. With iBridge, editing and adding Z-Wave devices is made easy, and uniquely remote-configurable by dealers from their own smart devices, smart phone or iPad/tablets. No trucks need to be rolled to amend security system or Z-Wave device settings, scenes or schedules. Cloud-backup utility -Keep a complete backup for account's Z-wave device names, scenes, triggered events & scheds.

Tablet, Z-Wave Home Controls Module



SECURITY



VIDEO



CLIMATE



LIGHTING



LOCKING

iBridge on the wall



Optional 7" Portable WiFi web-enabled iBridge Tablet with voice prompts, on Magnetic Wall-Mount Dock/Charger.

Optional iBridge Touchscreen/Tablet - Great new RMR-generating remote individual or bundled services for new & existing accounts.

Wall-Mountable Touchscreen/Tablet, IBR-ITAB:

- **Optional Portable 7" Tablet/Touchscreen with 802.11 wireless technology** (Hardwired option, too. See full ordering info next page.)
- **100% Mirrors all functions of the iBridge App plus adds voice-prompts for ease of use**
- **Touchscreen control of security system, video and automated home controls from anywhere in the home**
- **Integrated video viewing of iSee Video Cameras, inside & out** - See six at once, or any one in close up (p/t controls too).
- **Easy on/off combo. magnetic wall mounting frame/charging dock**
- **Home-Screen Dealer Customization utility** -Keeps your name, logo & contact info in front of your customers
- **Color full-screen TFT high-resolution display** (800 x 480)
- **Z-Wave Lighting, lock and thermostat control integrated using Z-REMOTE Module (opp. page). Scheduling & intuitive scene creation & control.**
- **Internet browser-enabled**
- **On-screen tools:** Photo gallery, time, weather, Panic buttons, Alarm Status, brightness, volume, etc.
- **Thin, slim profile, approx. 8 x 5"**
- **Tabletop stand also available**

3 TYPICAL CONFIGURATIONS FOR USE WITH ANY NAPCO SECURITY SYSTEM:

NO iBridge Tablet / iBridge App for Smart Devices

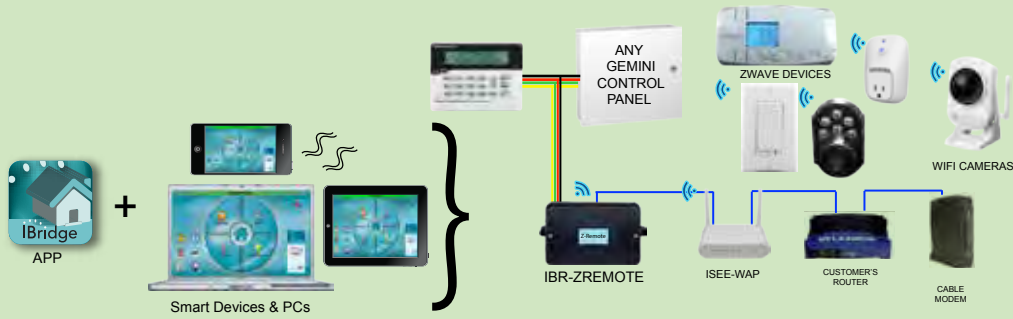

With Wireless iBridge Tablet



With Hardwired iBridge Tablet

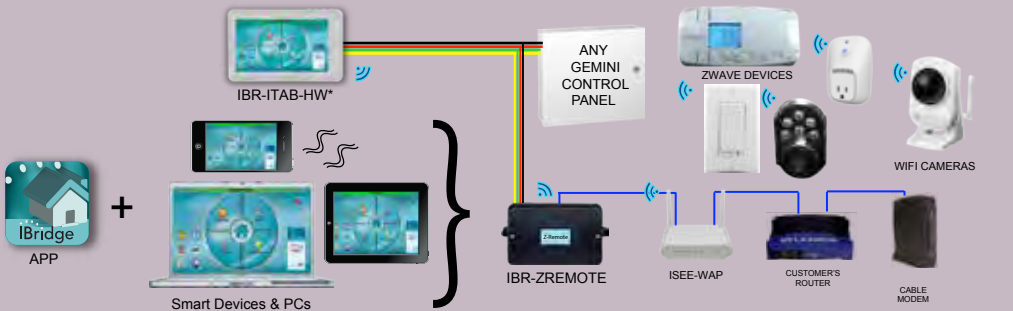

* Optionally add WiFi IBR-ITAB Tablets to this Configuration, too.

IBRIDGE ORDERING INFORMATION:

IBR-ZREMOTE Bus-Mount Module for remote, control, up/download of security system, **plus** control of Z-Wave devices, lights, locks, thermostat, etc.

IBR-ITAB iBridge Touchscreen Tablet with mounting frame and charging station.

IBR-ITABKIT Kit: iBridge Touchscreen Tablet with mounting frame/charging station plus Wireless Access Point (ISEE-WAP).

IBR-ITAB-HW Hardwired iBridge Touchscreen Tablet version for permanent mounting and more conventional hardwire installation.

ISEE-WAP Wireless Access Point

IBR-ITABSTAND Angled tabletop stand/docking station for use with IBR-ITAB Touchscreen (not included). Deco-neutral and ideal for bedrooms, kitchens, desks, etc.

IBR-WIFI-MOD Wireless Panel Interface, communicates between internet, Gemini Panel and IBR-ITAB WIFI Touchscreen Tablet, when NO remote services are used. **(Note: For remote services, use Z-REMOTE or IREMOTE with ISEE-WAP.)**

FOR FULL LIST OF COMPATIBLE Z-WAVE DEVICES please see "iBridge Evaluated Devices", online in the Napco iBridge section, www.napcosecurity.com/ibridge.html

(Note: iBridge Touchscreen can be the primary keypad on the system as shown, some restrictions may apply.)

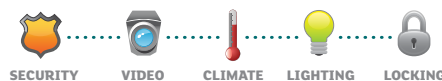

iSeeVideo is Easy!

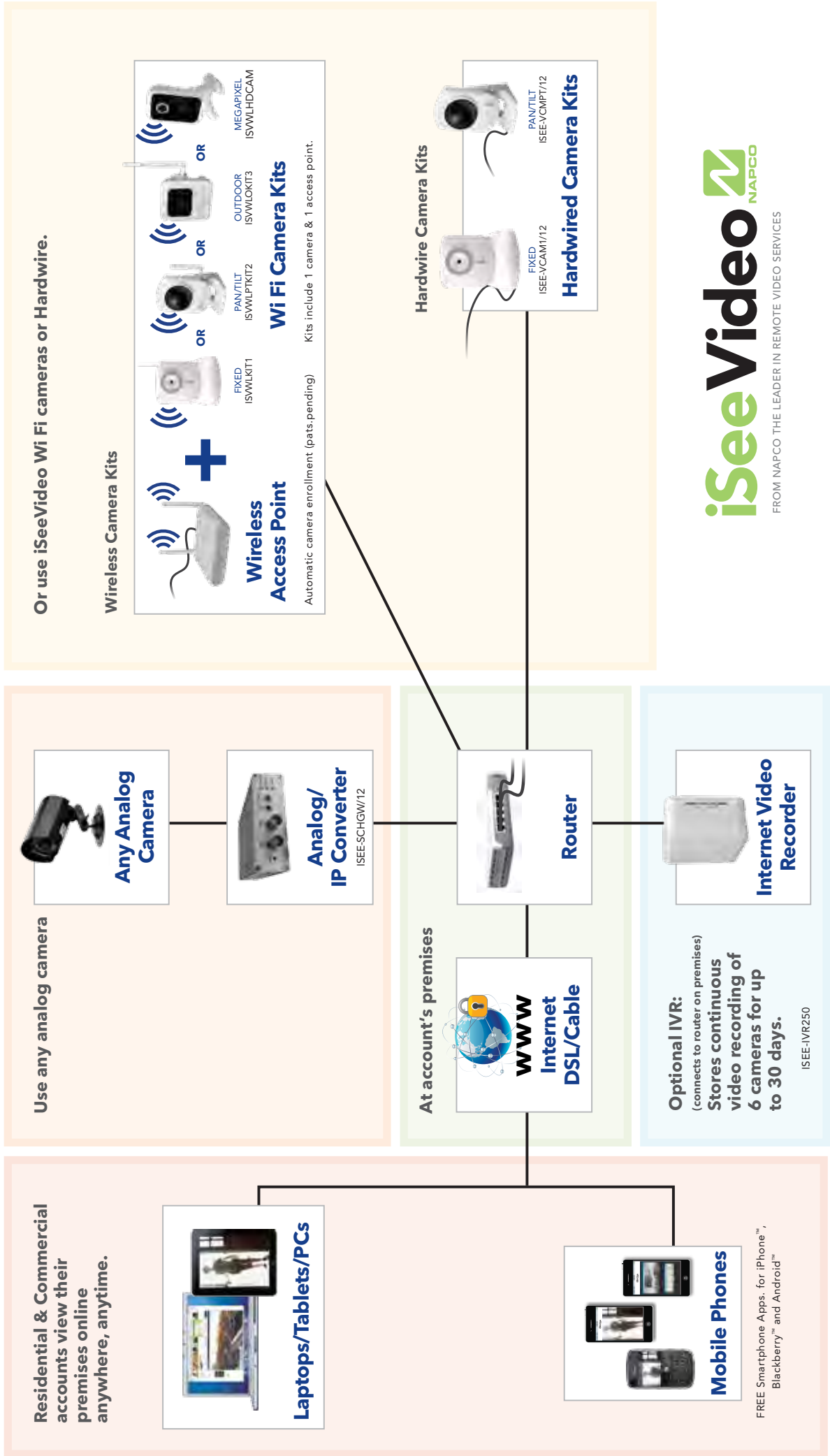

FROM NAPCO THE LEADER IN REMOTE VIDEO SERVICES

iSee Video™: Affordable Professional Quality Hi-Res. Remote Video pioneered by Napco...

iSee Video

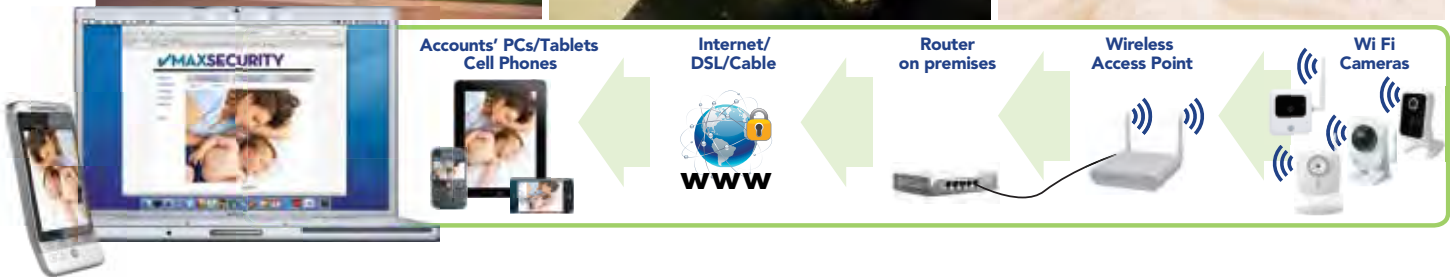

App

iSee Video™: Affordable Professional Quality Hi-Res. Remote Video pioneered by Napco...

Napco pioneered remote video and today's iSee Video is the reliable, easy-to-install, ideal upsell solution for residential & smaller commercial accounts alike.

It's the affordable remote video service accounts want, where kids, pets, elders or employees, boats or vacation homes are viewable on any PC or smartphone anywhere, 24/7. They'll view live streaming video, archived or emailed events from a supplied secure multilingual website we provide, that security companies can customize with their logo, phone, URL and contact info. It can be deployed with any of three indoor or outdoor iSee Video 802.11 WiFi Camera, with a secure-networked installation in as little as 10 minutes, or

you can use your choice of analog camera brand, instantly converted to IP cameras with our Video Gateway. Both methods give you and your residential or commercial customers the high-res. professional quality iSee Video online remote video service you'd expect from Napco.

And, now iSee Video is a featured application integrated in the iBridge suite of interactive online services, including the iBridge App for Smart Devices and on the iBridge Touchscreen/Tablet Computer.

(see pages 10-12)



iSeeVideo™ Remote WiFi Video: The easiest, the first, the best.



iSee Video shown on iPhone and iPad, along with outdoor camera, wireless access point and optional, full-time unique Internet Video Recorder.

WiFi, Hi-Res., streaming video, viewed 24/7 on-the-fly or capturing an event, sent to client's smartphone or computer online, anywhere.

Fast installs with WiFi indoor/outdoor cameras that auto-enroll and secure-lock their video network. Hi-res full-frame viewing, and fastest frame rate for live streaming video – not herky-jerky little screens that can't be blown up.

WiFi Camera Features

- **Put video accounts online in as little as 10 minutes**
- **Upsell your residential & small business alarm accounts** on very affordable video for incremental RMR
- **Highest resolution** remote video on the market! 20 frames per second @ VGA res. (640x480)
- 802.11 cameras easily enroll on network with patented wireless access point's auto-detect mode (All have a hardwire jack option too.)
- **Free Apps.** iPhone/iPad, Blackberry, Droid.
- **Professional quality** -View online in quad screen configuration or by-camera, Quickly review archived video with film-strip style thumbnails with time/date-stamp
- **Customize with your company logo & phone** on view screen to keep your name in front of accounts
- **Choice of Wi-Fi Cameras**, pan & tilt, outdoor/waterproof or fixed IP, in all-inclusive turnkey kits, include one year of subscriber service. Also, new Megapixel Camera with IR and built in PIR (shown).



Our Camera or Yours...

Put any analog camera of any brand online easily with iSee Video remote service using the **Single Channel**

Gateway, model ISEE-SCHGW/12, that instantly converts any analog CCTV camera into a high-res. internet-ready IP camera online (use up to 6 per account). Streaming or stored video can then be remotely accessed anywhere in the world, 24/7, from any web-enabled computer or smartphone with Free Apps. for iPhone/iPad, Blackberry, Droid. Plus using optional alarm system input triggers, video can be automatically captured and/or emailed to accounts upon alarm events, such as business opens/closes, returning children (disarm), retiring of elder parent (arm), departure of staff (cleaning people or service contractors).

Single Channel Gateway Features

- **Simply plug the CAT5 cable into premises' router** and the camera will automatically adapt to the network regardless of service and modem type. Even in the most inflexible corporate networks, the video camera will auto-configure through the network to iSee Video's www.videoalert.net server.
- **Professional widescreen VGA, high-res.** video images of 704 x 480, max.using MPEG4 compression
- Fast 20FPS video viewing on the Napco-provided server including 12-months subscriber access to 50MB of video storage. Or, for full-time recording, use the affordable iSee Video Internet Video Recorder (IVR250, below).
- View online in quad screen configuration or by-camera, Quickly look-up archived video with film-strip style thumbnails with time/date-stamp
- -or- advanced pixel-based motion detection on demand or on event, can transmit video clips to the www.videoalert.net server and/or provide a "video alert" to the account's smart phone/tablet
- **Local TV viewing option** Gateway provides a local video output for optional signal for BNC video-in/-out connection to a monitor, or for local distribution, using a video modulator. –Great for viewing outdoor cameras while clients remain safe & comfortable inside.
- Free Dynamic IP support

ISEE-IVR-250: Record up to 90 days of continuous video - playback and control online.

IVR250

iSee Video Internet Video Recorder for Full-Time Recording

- Continuously record and store up to 30 days of video from up to six iSee Video System cameras with our new Internet video recorder (ISEE-IVR250)
- Record high resolution video, with continuous recording of up to four cameras at 20 FPS. Add two more with virtually no loss of image quality thanks to Dynamic Image Reduction
- Easy retrieval and viewing by the online subscriber from password protected online interface which offers user-friendly navigation aids, quick-review/locate/calendar-lookup tools, time-/date-stamped video and an easy-to-use file-export utility.



- Dually supervised; plug and play setup - no software to load or configure
- Safely stores video on iSee Video server, provided. Easy, secure internet access, retrieval and video look-up
- **Provide more reliable video recording and get monthly RMR instead on a one-time DVR hardware sale!**



ISEE VIDEO ORDERING

ISVWLKIT1 Complete Wireless Camera Kit: One (1) 802.11 Wireless Fixed Camera, 640x480 hi-res, power adapter, Patented automatic-enroller Wireless Access Point (WAP) Module & power adapter. Includes custom dealer website log-in screen and 12-months iSee Video Network access. (Kits support up to 6 cameras).

ISVWLPTKIT2 Complete Wireless P/T Camera Kit: Kit as above but with one (1) 802.11 Wireless Pan/Tilt Camera, 640x480 hi-res.

ISVWLOKIT3 Complete Wireless Outdoor Camera Kit: Kit as above but with one (1) 802.11 Wireless Weatherproof (IP65) Fixed Camera, 640x480 hi-res, with built-in PIR motion detector, 6 IR LEDs with photo cell activation and night vision filter, power adapter.

ISVWLHDKIT4 Complete Wireless Megapixel Camera Kit: Kit as above but with one (1) 802.11n Wireless HD Megapixel Camera, : 720p HD (1280x720), Infrared (IR), built in PIR (3.8"H x 2.5"W x 1.4"D (plus base, approx 3"sq.); power adapter.

ISVWLCAM Add-on 802.11 Wireless Fixed Camera: 640x480 hi-res AC transformer. Includes 12-months iSee Video Network access. For Hardwire-Only version order ISEE-VCAM1/12

ISVWLCAMPT Add-on 802.11 Wireless Pan/Tilt Camera: 640x480 hi-res, power adapter. Includes 12-months iSee Video Network access. For Hardwire-Only version order ISEE-VCMPT/12

ISVWLOCAM Add-on Wireless Outdoor 802.11 Camera: Weatherproof (IP65) Fixed Camera, 640x480 hi-res, with built-in PIR, 6 IR LEDs with photo cell activation and night vision filter, power adapter. Includes 12-months iSee Video Network access.

ISVWLHDCAM Add-on 802.11 Wireless HD Megapixel Camera with Infrared (IR) and built in PIR: 720p HD (1280x720), IR, PIR, AC transformer. Includes 12-months iSee Video Network access.

ISEE-SCHGW/12 Single Channel Gateway for more conventional CAT5 or Coax Installations: (1) ISEE-SCHGW widescreen. VGA Res (704 x 480) at up to 30 FPS, MPEG4 compression, audio mic input and speaker output. Includes 12-months iSee Video Network access.

ISEE-IVR250 Optional - Internet Video Recorder: Provides full-time hi-res recording of up to 6 cameras for 30 days (640x480).

ISEE-IVR-1T: Fulltime recording 6 cameras at least 90 days.

Gemini Remote Virtual Keypad Module & App:

Easy affordable system control on-the-go.

iRemote



"My Remote Keypad" App for iPhone/iPad and Droid.

IREMOTEMOD/12

- **Remote keypad access anywhere, works & looks like any Gemini keypad model.**
- Supports all Gemini model panels and keypads
- Remote control Gemini Virtual Keypad with Free 12-months account access on Free custom dealer web site
- Simply wire iRemote™ Module on the panel's keypad bus.
- Exactly mirrors keypad on premises for easy 24-7 control via web and PC or smartphone
- 100% full-function "keypad" for easy remote troubleshooting without making a service call

- Bonus functionality - Up/download to panels via internet in just seconds; alarm reporting to central station via internet
- **Free downloadable apps for iPhone/iPad, Blackberry, Android**
- **Panel Compatibility GEM-X255, GEM-P9600, GEM-P3200, GEM-P1664, GEM-P1632, GEM-P816**

ORDERING:

- **iRemoteMod/12** Module with 12 months subscriber access, included
- **iRemote64Pak** with GEMP1664 4-Area Panel, Talking GEMK1VPS Keypad and transformer, and iRemoteMod/12.

WIRING OF IREMOTE MODULE ON KEYPAD BUS

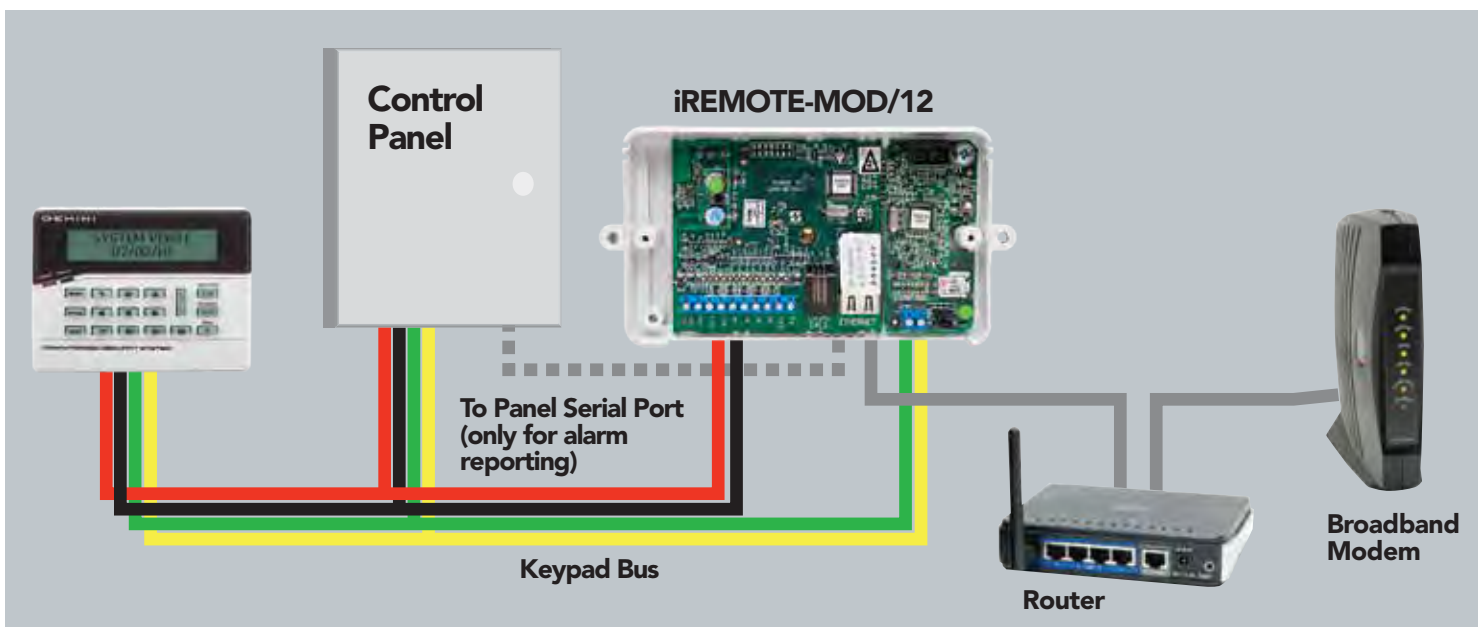

Gemini System Control - More Smart Choices in Keypads...

Pick your keypad; Your way. And, don't forget the one for their smart phone!

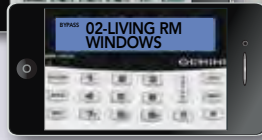
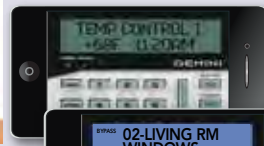

Also see Remote Keypad Interfaces for Smart Devices and Phones, inclg iBridge and iRemote, for all Gemini Panels, pgs 9, 10, 11 & 17.

		GEMINI PANELS							
		GEM	P816	P1632	P1664	P3200	P9600	X255	P801
GEMINI KEYPADS	STAY & AWAY	K1CA/DK1CA	•	•	•	•	•	•	•
		K1VPS	•	•	•	•	•	•	•
		K2AS	•	•	•	•	•	•	•
		K3DGL/DK3DGL	•	•	•	•	•	•	•
		K4RF	•	•	•	•	•	•	•
CLASSIC		K4	•	•	•	•	•	•	•
		RP1CAe2	•	•	•	•	•	•	•
		RP2ASe2	•	•	•	•	•	•	•
		RP3DGL	•	•	•	•	•	•	•
		RP8LCD	•	•	•	•	•	•	•
	RP8/K800	•	•	•	•	•	•	•	



K-Series:
Intuitive, stay & away ease-of-use



RP Series:
Traditional interior and instant keys



Custom alphanumeric keypads

GEMK1CA and GEMRP1CAe2

- Deluxe 32-character backlit, menu-driven, dual-line display
- Custom alphanumeric zone directory
- Built-in 4 Zone expansion module
- Display of wireless transmitter signal strength 1-10
- EZ Keypad Programming2 with actual Q&A's
- Intuitive, stay & away ease-of-use buttons, for easy one button arm and easy instant (hold-down) with the GEMK1CA. Traditional interior and instant keys with the GEMRP1CAe2
- Large soft touch backlit keys with tone
- Backlit displays for easy reading
- Wireless transmitter signal strength indication
- Fire, police and auxiliary programmable panic keys
- Fingertip reference chart



Alpha/symbol keypads

GEMK2AS and GEMRP2ASe2

- Unique backlit, combination alphanumeric and symbol display
- Intuitive, stay & away ease-of-use buttons, for easy one button arm and easy instant key (hold-down) with the GEMK2AS. Traditional interior and instant keys with GEMRP2ASe2
- Large soft touch backlit keys with tone
- Backlit displays for easy reading
- Wireless transmitter signal strength indication
- Decor friendly soft white design
- Fire, police and auxiliary programmable panic keys
- Fingertip reference chart



Talking, Multifunction Keypad with voice assist, UL siren & pet PIR built in

GEM-K1VPS

- For use with GEMP1664 and GEMP1632 Panels, for 64 or 32 user codes, each
- Talking voice prompts (adjustable volume)
- Large blue custom alpha display
- Built-in 88db burg/fire alarm siren (temporary hush mode)
- Built-in wide-angle 25' pet PIR and smart occupancy sensor
- Supports event log viewing
- **Optional temperature display (with GEM-TEMP64 module)** (see Gemini Accessories pg. 21)



Door style keypads

GEM-DK1CA

- Contemporary, pure black and white styling
- Door covers keys for cleaner lines & prevents unwarranted use
- Bright blue backlit custom LCD display & alphanumeric zone directory
- Blue backlit keys brighten to the touch and feature easy stay and away functionality
- Built in 4-zone expander
- 3 built in panic buttons
- Familiar Napco operation, identical usage and programming to GEM-K1CAe2
- Distinctive new look distinguishes dealers from competitive alarm companies

(Also available in digital model GEM-DK3DGL, shown right)

Even Right on Accounts' Smart Phone or Tablet



Keypad with built in wireless 32 pt. Gemini RF receiver

GEMK4RF

- Built-in 32 Point Gemini wireless receiver for labor-saving convenience
- Large backlit, fixed English display
- Proven crystal-control wireless performance
- Supports all Gemini transmitters
- Intuitive, stay & away ease-of-use buttons, for easy one button arm and easy "instant" (hold-down)
- Large soft touch backlit keys with tone
- Wireless transmitter signal strength indication
- Decor friendly soft white design
- Fire, police and auxiliary programmable panic keys
- Matching keypad without-receiver GEMK4



Digital keypads

GEMK3DGTL and GEMRP3DGTL

- Vivid dual 7-segment digital display keypad



Gemini BioReader Outdoor Digital / Fingerprint Keypad

GEM-BIOREADER/MS

- **Indoor/outdoor digital keypad with a highly-advanced and accurate optical biometric fingerprint reader** for integrated control of any Gemini security system or as state-of-the-art standalone access control use for alarm systems, garage door operator control, lighting, etc. with relay activation.
- Increases the security of the system Biometric ambush feature sends silent alarms. Use pre-selected and enrolled finger to silently call the police during push ins and robberies
- Convenient for consumers- No keys or cards to carry, no codes to memorize and remember

800-Series' classic custom alphanumeric keypad with stay & away keys



GEMRP8LCD

- Deluxe 32-character backlit dual-line custom alpha display & directory
- Built-in 2 zone expansion module
- Display of wireless transmitter signal strength
- EZ Keypad Programming2 with actual Q&A's to step through configuration
- New intuitive, stay & away ease-of-use buttons, for easy one button arm and easy "instant" (hold-down)



GEM-K800 and GEM-RP8 numeric LED keypads

- Backlit keys and vivid red LED numeric display
- Traditional-key style
- **GEM-RP8** supplied with GEMP801/P800
- Stay & Away version GEM-K800 available



Express LED/Door Keypads (for Express panels only)

RP-X6 & RP-X4

- Door-styling, conceals keys Backlit keys and
- Multilingual, vivid LED symbol & numeric display
- RPX-6 supplied with XP600; RPX-4, with XP400



- Eliminates code pass-along. With children or employee-turnover - you can't pass along a fingerprint!
- Users. System supports 100 biometric fingerprints, that can be mapped to Panel User Codes for logging who armed/disarmed.
- Supervised (e.g., reports if unit is ripped from building)
- Durable metallic silver powder-coat finish.

Residential applications Keyless use ideal for children; Memory-free for elderly; Easy Residential alarm and garage door control.

Commercial applications such as gate control and parking lot access; restricted access to sensitive pharmaceuticals, weapons, supplies and more.

Napco StarLink™ Universal GSM Alarm Communicators - SLE-GSM Series, Unprecedented Reliability Anywhere

Two Universal back-up or primary GSM alarm communicators

SLe-GSM Series Features:

- Universal full event reporting from **any panel** virtually anywhere to any Central Station (No radio activation fee. No special equipment.)
- Compatible with control panels that communicate using Contact ID and 4/2 format
- **Two Models: Original SLE-GSM or SLE-GSM-3/4G 3G/4G Network-Compatible**
- Full High-Speed Napco Panel remote uploading/downloading (2-way communications, requires high-speed cable)
- Signal-Boost Technology amplifies alarm signals and wave shapes for unprecedented reliability even in remote/fringe areas
 - Email/Text/SMS messages alerts, selectable option (SLe-SMS service).
 - 1-Step enrollment and programming built in, ready for most jobs. (Advanced programming options also available.)

- Automatic dialer-capture technology eliminates time-consuming web setup!
- Takeover Feature - Easily captures any panel's existing CS phone number and allows you to reroute it to another central station.
- Remote arm/disarm any panel brand with a keyswitch input (SLe-REMOTE selectable service option). Free App.
- For backup radio mode –supervises telco and only sends GSM reports when it's not functioning
- Future-Proof Field-Upgradeable Communications Technology - The only alarm communicator in the category that is plug-in field upgradeable to conform to progressions in network technology -- to move to the latest eg., 2G, 3G,...5xG, etc. (See ordering info for field upgrade kit and choice of radio models.)
- Includes SIM card and dual band high-efficiency antenna
- Optional Smart Charger Module for use when panel aux power is at a premium and/or for optimized radio mounting locations up to 100' from the panel (Module maybe used with or without its own 4AH/12V battery).

ORDERING INFORMATION

SLE-GSM: GSM Communicator, SIM card. Service plan(s) sold separately. *No Activation Fee.*

SLE-GSM-3/4G: 3G/4G Network Compatible GSM Universal Wireless Alarm Communicator, SIM card. Service plan(s) sold separately. *No Activation Fee.*

SLE-UPGRD-3/4G: 3G/4G Network Field Upgrade Kit, For Use With SLe-GSM Universal Wireless Alarm Communicator

SLE-DLCBL: For use with Gemini Panels only, Napco Up/download cable, sold separately.

SLE-1632INTROPAK: "RAD-PAK" (Panel with Radio). SLE-GSM StarLink 2 Radio, Gemini P1632 32-Zone Panel, GEM-RP1CAe2 Custom Alpha Keypad, SLE-DLCBL Radio Up/Download Cable & Panel Xformer.

SLE-REMOTE: Remote App for arming, disarming panel via wireless radio. (Requires service upgrade.)

SLE-DLEXT: Optional, for up/downloading, extends distance from radio to panel, from 10', up to 100 ft.

A606: Free Trifold Enduser Brochure for new and existing accounts. Statement Stuffer or Self-Mailer

SLE-SMTCHG: Optional, Smart Charge Module. Allows for optimal radio position regardless of available AC outlets. Also ideal where auxiliary (fire) standby power is too low - without requiring a separate power supply. Uses standard 4AH/12V rechargeable battery.

SLE-GSMET: GSM Communicator in metal housing (also accommodates 4 Ah /12V rechargeable battery), SIM card included.

3G/4G Ready

SLe-GSM Series



Free Sales Trifold Mailers for New & Existing Accounts (Part No. A606)

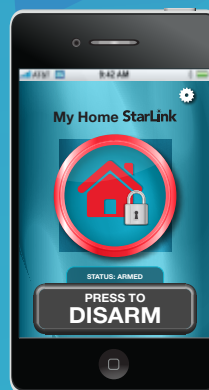
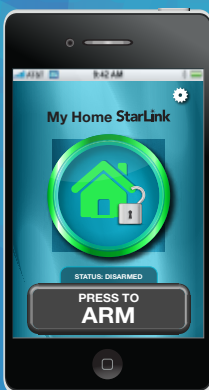

App

"My Home StarLink" App available for Android and iPhone/iPad.



NAPCO Alternative Alarm Reporting Solutions: Internet Alarm Communications

NetLink™ Alternative Alarm Reporting & VoIP Solution

NetLink Panel Modules

NL-MOD & NET-COMM

- Communicate alarms via Internet or intranet over a TCP/IP-based network using dynamic IP addressing
- Secure transmissions over the Internet using AES128bit encryption
- Use for primary and/or backup reporting
- **NL-MOD** NetLink Module can be used with any Napco panel, from the **GEMP816 to the X255 and Gemini-Commercial (GEM-C)** to securely communicate alarms, status, supervisories, etc, pinpointed by-zone
- **NET-COMM** Economy NetLink Module, is similar, and this less expensive communicator is driven directly by the alarm panel. It supports 5 channel reporting codes, communicating, for example, alarms, panics, fire, telco failure, low battery, etc.



NetLink Receiver for UL Central Station applications:

NL-RCV-RMPCUL

- Both NetLink modules report via TCP/IP to any central station or intranet facility with the NetLink UL Listed Receiver (model **NL-RCV-RMPCUL**)
- UL864/UL1610-listed advanced, rack-mounted receiver
- Interfaces with the conventional Central Station automation system
- 2 Reception Modes: **Automatic Mode**, where alarm signals are sent normally to the automation system for processing -or- **Manual Mode**, used when direct operator interaction is desired, using the built in menu-driven keypad-style alphanumeric interface
- For redundant/mirrored applications -Two can be simply crossover-cable networked
- **Compliances:** UL864 (Control Units for Fire Protective Signaling Systems); UL1610 (Central Station Burglar Alarm Units).

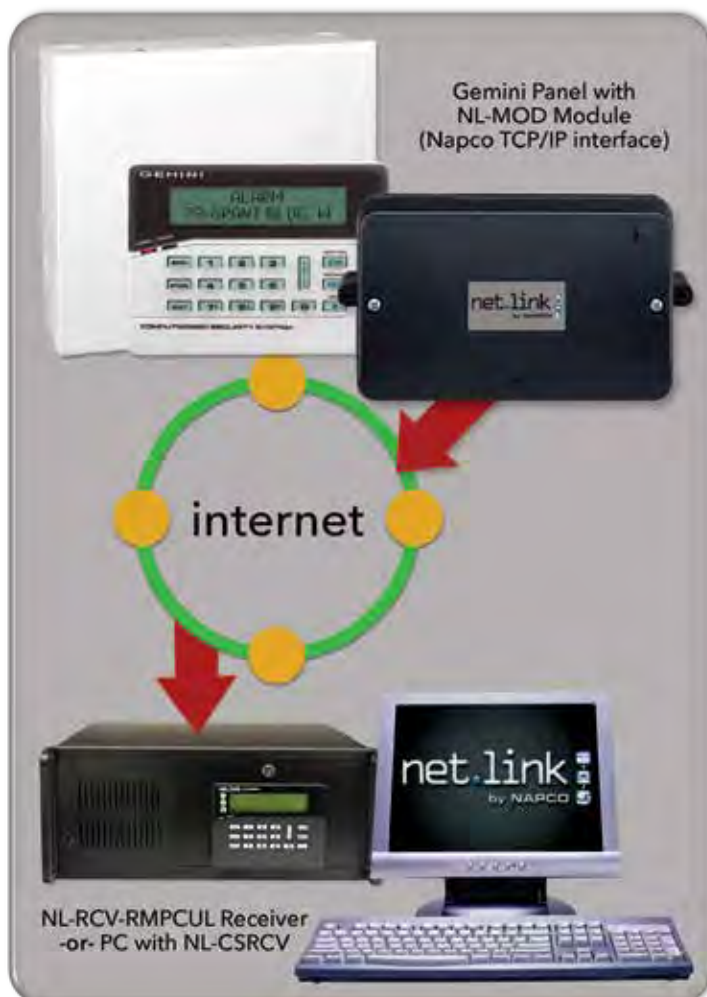



Expandable Gemini hybrid controls feature:

- Wide choice of designer keypads for every application and budget (see p. 8)
- Use new **iBridge App & Touchscreen/ Tablet** for integrated security, climate, lighting or video control or **iRemote Virtual Keypad** (for smartphone or computer remote interface) in place of any custom alpha keypad
- Up/downloading, including unique PC-preset unattended method with PCD-WINDOWS
- EZ-Programming mode at keypad
- Choice of Gemini RF receivers & transmitters
- Multi-stage lightning protection
- Event log with open/closes suppression
- Telco line cut supervision
- Fuseless, maintenance-free operation
- Support all major communication formats plus **internet & StarLink GSM Radios**, universal primary/backup communicator (hi-speed up/downloads from Gemini Panels)
- Transformer, supplied

Gemini X255 is the expansive hardwire/ wireless control offering 255 fully-programmable zones, 195 users, fuseless operation & supports the full line of top performing Gemini Wireless

Features:

- 8 to 255 hardwired zones or wireless zones/pts
- Expandable using 8-zone GEM-EZM8 expansion modules
- Up to 96 fire zones, with 8 2-wire fire zones
- Up to 8 areas
- Up to 195 user codes with open/close by user
- 3 On-board relay output & 1 prog. lug
- Up to 96 relays
- Supports 4 wireless receivers
- Supports 15 GEMRP1CAE2 or K1CA keypads
- Up to 2 interior bypass groups
- 800 Event log w/ open/close suppress
- Auto arm/disarm
- 255 Event scheduler
- GEM-ACCESS access control compatibility

Gemini P9600 powerful multi-tasking hybrid control panel - feature-rich for security applications and home automation integration

Features:

- 8 to 96 hardwire zones/points
- Including 8 2-wire fire zones
- Up to 96 user codes
- Up to 8 areas
- 3 On-board relay outputs; expandable to 96
- 1 On-board programmable lug
- Up to 4 RF receivers
- Up to 15 keypads
- Up to 2 interior bypass groups
- 800 Event log
- Auto arm/disarm
- 255 Event scheduler
- GEM-ACCESS access control compatibility

Gemini P3200, a popular, all-around 8 zone hybrid control expandable to 32 zones or 48 wireless points

Features:

- 8 to 32 hardwire or wireless zones/ points;
- up to 48 RF wireless points
- Including 2 2-wire fire zones

- Up to 48 user codes
- Up to 2 areas
- Fuseless, maintenance-free operation
- 3 On-board relay outputs; expandable to 24
- 1 On-board programmable lug
- Up to 2 RF receivers
- Up to 7 keypads
- Interior bypass groups
- 800 Event log
- Auto arm/disarm
- 255 Event scheduler
- GEM-ACCESS access control compatibility

Gemini P1664, 4-area hybrid panel with 8-64-zones of power; supports all keypads plus talking multifunction keypads with built in siren & pet PIR

- 8 to 64 hardwire or wireless zones
- Up to 64 fire zones, with 2, 2-wire fire
- Up to 64 user codes
- Up to 4 areas
- 400 event log; viewable at custom alpha keypads
- Up to 2 RF receivers
- EZ Programming at keypad and Auto Arm
- Supports up to 7 keypads: all standard Gemini Keypads and/or talking, multifunction GEM-K1VPS (may be intermixed)
- Supports 3 outputs; expandable up to 16 external outputs (RB/RM3008)
- 2 PGM outputs
- 1 interior zone group; 2 prog. chimes by zone;
- SIA CP01 features

Gemini P1632, ultra-popular hardwire/wireless control panel with partitioning - easy to standardize for both residential & light commercial applications

Features:

- 8 to 32 hardwire zones/points
- Including 2 2-wire fire zones (7;8)
- EZ programming at keypad
- Up to 32 user codes
- Up to 2 areas
- Supports up to 7 keypads and/or talking, multifunction GEM-K1VPS (may be intermixed)
- 3 On-board relay outputs; expandable to 8 relay outputs
- Up to 2 RF receivers
- Interior bypass groups
- 400 Event log
- Auto arm

Gemini P816, an economical hardwire/wireless control panel that works seamlessly with all standard Gemini keypads and wireless

Features:

- 8 to 16 hardwire zones/points
- Including 2 2-wire fire zones
- Up to 16 user codes
- Supports up to 7 keypads
- EZ Programming at keypad
- 256 event logging
- Supports 2 Gemini receivers
- Interior bypass group
- Auto arm
- 3 Outputs

Gemini P801, economical 9 zone hybrid with your choice of numeric or custom alpha keypads

Features:

- 9 Programmable zones: 6 Hardwire or wireless zones plus 2 wireless zones plus 2-wire fire zone
- Use 2 optional zones at GEMRP8LCD custom alpha keypad
- For Control packed with RP8LCD Custom Alpha Keypad, order **GEM-P801ALPHA**
- For control packed with RP8 Numeric LED Keypad, order **GEM-P801**
- Uses GEMRECVXP8 wireless receiver
- 8 Individually reporting user codes
- 50 Event log
- Line and bell-cut supervision
- Double reporting & backup reporting
- EZ wire full-size terminal strips

Gemini P800, ultra-affordable hybrid control includes numeric keypad and 6 zones plus fire and panic

Features:

- 8 programmable zones, including 2-wire fire zones
- Up to 16 Gemini wireless points: 8 wireless points from your choice of Gemini PIR, window/door & glassbreaks
- Up to 4 Gemini wireless smoke detectors and 4 GEMKEYF fobs
- 8 individually reporting user codes
- Supports up to 4 GEM-RP8 keypads &/or 2 wireless receivers (GEM-RECVXP8)
- Supports GEM-R8LCD/K800 Custom Alpha Keypad
- Includes control, Numeric LED Keypad and transformer

Gemini Accessories

GEM-EZM4/8 Expansion Module

- Economy 4 to 8 zone expansion module supports GEM-P816, GEM-P1632 & GEM-P1664

GEM-EZM8 Expansion Module

- Eight-zone expansion module (for all expandable GEM panels. Audible find mode)

GEM-PRINT

- Module that enables Gemini system activity to print to an on-site parallel printer
- For use with GEMP816 to X255 Controls

IREMOTEMOD/12

Gemini Virtual Keypad module provides a mirror-image, fully-functional, remote control keypad on a on any PC or smartphone online anywhere in the world (free apps for all smart devices.) Module simulates real keypad model at physical premises and simply wires on GEM-Panel's keypad bus. (see page 13)

IBRIDGE & IBR-ZREMOTE MODULE

iBridge App for iPhone/iPad & Droid smart devices or optional **iBridge Touchscreen/ Tablet IBR-ITAB** wireless WiFi 802.11 portable full-color tablet with on/off magnetic wall-mount/charger dock. Control alarm & video plus lights, temp., locks with bus-mount Z-Wave Module plus Z-Wave Devices. For GEM Panels, X255 thru P816 (see page 11).

GEM-TEMP64

Indoor/Outdoor Temperature Sensor

provides Temperature Display at any Gemini Alphanumeric Keypad in a GEMP1632 and GEMP1664 System. Keypad will show Temperature in display, from -30 to 60C or -22 to 140F (replacing "Date" on keypad-display), e.g., GEMK1VPS, GEM-DK1CA, GEM-K1CA, GEM-RP1CAe2. Module is mounted inside or outdoors, to display either the temperature outside or inside room temperature. Tip: If used with IREMOTEMOD Module (below), the virtual keypad shown on the consumer's iPhone or laptop includes that temperature. Example, in a remote vacation home or hunting cabin, the unit can be mounted inside so endusers can check in remotely from anywhere, and make sure the room temp. is sufficient, preventing frozen/burst pipes etc., likewise knowing if and when an HVAC system fails, can help prevent damage/molds in heat.

Express Systems with multilingual LED XP keypads

XP400WK, XP600WK, respectively

- Feature-rich programmable zones:
- 4 in XP400 -or- 6 in XP600
- Support all Gemini wireless transmitters
- using Gemini GEM-RECVXP8
- Includes multilingual LED keypad (suffix - SN for Spanish language zone dir'y); RP-X4 for XP400 or backlit RP-X6 for XP600
- Keyfob support: 2 or 4, respectively
- Plus 4 or 8 pts, respectively, for RF points from choice of PIR, window/door & glassbreaks
- Plus XP600's 2-wire fire zone also supports 4 wireless Gemini smoke detectors
- 4 or 6 Individual user codes, respectively
- Available in 4-Paks with 4 keypads, part no. XP400/4 or XP600/4

Comparison of Gemini® panel features & accessories

FEATURES	GEMINI ALARM PANELS			
	GEM-P400	GEM-P800	GEM-P801	GEM-P816
ZONES ON BOARD	(acts as) 4	(acts as) 6	8	8
MAX. # ZONES	4	6	9	16
ZONE EXPANSION (NOTE: Each Custom Alpha Keypad adds 4 Built-in Zones) (2 on RP8LCD)	-	2 Wireless Only Zones	2 Wireless Only Zones	2xGEM-EZM4/8 1xGEM-EZM8
USER CODES	4	8	8	16
# OF FIRE ZONES; 2 WIRE FIRE	-	1 2/4 WIRE	1 2/4 WIRE	UP TO 16; 2 2-WIRE
KEYPADS OR USER INTERFACES SUPPORTED	4(total) GEM-RP4 or GEM-K400 IREMOTEMOD/12	4(total) GEM-RP8 RP8LCD or GEM-K800 IREMOTEMOD/12	4(total) GEM-RP8 RP8LCD or GEM-K800 IREMOTEMOD/12	7 (total) GEM-RP1CAe2 RP2ASe2 RP3DGTL or GEM-K1CA K2AS K3DGTL or DK1CA DK3DGTL, K4RF, K4 -PLUS- IREMOTEMOD/12; iBridge App or IBR-ITAB Touchscreen
EVENT LOG	-	50	50	256
# OF AREAS	1	1	1	1
# OF OUTPUTS	2	2	2	3
# OF WIRELESS RECEIVERS SUPPORTED	2 (GEM-RECVXP8 only)	2 (GEM-RECVXP8 only)	2 (GEM-RECVXP8 only)	2 (GEM-K4RF, RECV32)
# WIRELESS POINTS	4	8	8	16
# WIRELESS KEYFOBS	2	4	4	8
AUTO ARM	-	-	-	YES
OPEN/CLOSE SUPPRESSION	-	-	-	YES
AUTO DISARM	-	-	-	-
SCHEDULES	-	-	-	-
LINE CUT DETECT	YES	YES	YES	YES
BELL SUPERVISION	YES	YES	YES	YES
COMMUNICATION FORMATS	CONTACT ID; 4/2	CONTACT ID; 4/2	CONTACT ID; 4/2	CONTACT ID; 4/2, SIA
INPUT POWER	16.5 VAC	16.5 VAC	16.5 VAC	16.5 VAC
MAX STANDBY CURRENT	350mA	500mA	650mA	650mA
ALARM CURRENT	2 AMPS	2 AMPS	2 AMPS	2 AMPS
AVAILABLE IN THESE CONFIGURATIONS	GEM-P400/4 4 Pak of Controls, Keypads & Transformers	GEM-P800 Control, Keypad & Transformer	GEM-P801 Control, RP8 Keypad & Transformer	GEM-P816 Control & Transformer.
		GEM-P800PAK Control, Backlit GEM-RP8 Keypad, Transformer, Siren, PIR 1500, Jack, Cord, 4AH Battery	GEM-P801ALPHA Control, Custom Alpha RP8LCD Keypad & Transformer	816PERFPAK Control, GEM-RP3DGTL Keypad, Transformer Also, K816PERFPAK , same but w/ GEMK3DGTL stay away style keypad
		GEM-P800PAK2 Control, Backlit GEM-RP8 Keypad, Transformer, Siren, PIR1680, Jack, Cord, 4AH Battery	801LCD-SUPERSVR Control, Custom Alpha RP8LCD Keypad, Siren, PIR1680PT, Jack, Cord, 4AH Battery & Transformer	816PERFPAKPLUS Control, GEM-RP3DGTL Keypad, Transformer, Siren, PIR, Jack, Cord, 4AH Battery Also, K816PERFPAK , same but w/ GEMK3DGTL stay/away style keypad
			801KSUPERSAVER Control, K800 LED Keypad w/Stay/Away Keys, Siren, PIR1680PT, Jack, Cord, 4AH Battery & Transformer	816PREMPAK Control, GEM-RP1CAe2 Keypad, Transformer Also, K816PREMPAK , same but w/ GEM-K1CA stay/away style keypad
			801SUPERSAVERPK as above but with RP8 LED Keypad with classic RP Keys	K816RFPK Control, GEM-K4RF Keypad w/ built in 32-pt RF Receiver and stay/away style keys, Transf.

GEMINI ALARM PANELS

GEM-P1632	GEM-P1664	GEM-P3200	GEM-P9600	GEM-X255
8	8	8	8	8
32	64	32/48	96	255
6xGEM-EZM4/8 3xGEM-EZM8	GEM-EZM4/8 GEM-EZM8	3xGEM-EZM8	3xGEM-EZM8 1xGEM-EZM8	GEM-EZM8 31xGEM-EZM8
32	64	48	96	195
UP TO 32; 2 2-WIRE	UP TO 64; 2 2-WIRE	UP TO 32; 2 2-WIRE	UP TO 96 WITH UP TO 8 2-WIRE FIRE	UP TO 255 WITH UP TO 8 2-WIRE FIRE
7 (total) GEM-K1VPS, K1V, RP1CAe2 RP2ASe2 RP3DGTL or GEM-K1CA K2AS K3DGTL or DK1CA DK3DGTL, K4RF, K4 -PLUS- IREMOTEMOD/12; iBridge App or IBR-ITAB Touchscreen	7 (total) GEM-K1VPS, K1V, RP1CAe2 RP2ASe2 RP3DGTL or GEM-K1CA K2AS or DK1CA DK3DGTL, K3DGTL K4RF, K4 -PLUS- IREMOTEMOD/12; iBridge App or IBR-ITAB Touchscreen	7 (total) GEM-RP1CAe2 RP2ASe2 RP3DGTL or GEM-K1CA K2AS K3DGTL or DK1CA DK3DGTL, K4RF, K4 -PLUS- IREMOTEMOD/12; iBridge App or IBR-ITAB Touchscreen	15 (total) GEM-RP1CAe2 RP2ASe2 RP3DGTL or GEM-K1CA K2AS K3DGTL or DK1CA DK3DGTL, K4RF, K4 -PLUS- IREMOTEMOD/12; iBridge App or IBR-ITAB Touchscreen	15 (total) GEM-RP1CAe2 GEM-K1CA GEM-DK1CA -PLUS- IREMOTEMOD/12; iBridge App or IBR-ITAB Touchscreen
400	400	800	800	800
2	4	2	8	8
3, UP TO 11 <small>(Using RB3008 Relay Modules)</small>	3 UP TO 16 <small>(Using RB3008 Relay Modules)</small>	3, UP TO 27 <small>(Using RB3008 Relay Modules)</small>	3, UP TO 99 <small>(Using RB3008 Relay Modules)</small>	3, UP TO 99 <small>(Using RB3008 Relay Modules)</small>
2 (GEM-K4RF RECV32/96)	2 (GEM-K4RF RECV32/96)	3 (GEM-K4RF RECV32/96)	4 (GEM-K4RF RECV32/96)	4 (RECV32/96/255)
32	64	48	96	255
8	8	8	16	16
YES	YES	YES	YES	YES
YES	YES	YES	YES	YES
-	-	YES	YES	YES
-	-	255	255	255
YES	YES	YES	YES	YES
YES	YES	YES	YES	YES
CONTACT ID; 4/2, SIA	CONTACT ID; 4/2, SIA	CONTACT ID; 4/2, SIA, Modem II	CONTACT ID; 4/2, SIA, Modem II, (RS232 output option)	CONTACT ID; 4/2, SIA, Modem II, (RS232 output option)
16.5 VAC	16.5VAC	16.5 VAC	16.5 VAC	16.5 VAC
650mA	650mA	650mA	750mA	750mA
2 AMPS	2 AMPS	2 AMPS	2 AMPS	2 AMPS
GEM-P1632 Control & Transformer	GEM-P1664 Control & Transformer	GEM-P3200 Control & Transformer	GEM-P9600 Control & Transformer	GEM-X255 Control & Transformer
1632PROPAK <small>Control, GEM-RP3DGTL Keypad, Transformer Also, K1632PROPAK, same but w/ GEMK3DGTL stay away style keypad</small>	GEM-P1664VPSPK <small>4-area control, Multifunction LCD Coded Talking Keypad w/built in UL siren, occupancy sensor and 25'Pet PIR (GEM-K1VPS); transf.</small>	Optional Mercantile Housing, H1217 or w/ unit GEM-P3200M	Optional Mercantile Housing, H1217 or w/ unit GEM-P9600M	
GEM-K120PAK <small>Control, Fixed LCD Keypad w/ built in 32pt RF Receiver and stay/away style keys, Siren, PIR1680PT, Jack, Cord, 4AH Battery, Transf.</small>	GEM-P1664DK1PK <small>4-area control, in oversized locking enclosure, Door-Style Keypad (GEM-DK1CA), transf.</small>			
1632INTROPAK <small>Control, GEM-RP1CAe2 Keypad, Transformer Also, K1632INTROPK, same but w/ GEM- K1CA stay/away style keypad</small>	IREMOTE64PAK <small>4-area control, Virtual Keypad Module (RemoteMod/12), Multifunction LCD Coded Talking Keypad w/built in UL siren, occupancy sensor and 25'Pet PIR (GEM-K1VPS); transf.</small>			
K1632RFPK <small>Control, GEM-K4RF Keypad w/ built in 32-pt RF Receiver and stay/away style keys, Transf.</small> GEM1632RECVPAK <small>Control, GEM-RP1CAe2 Keypad, Conventional 32 Pt. RF Receiver (GEMRECV32) , Transf.</small>				

Gemini Access: Add Access Control to Gemini Alarms from the P3200 to Gemini-Commercial Series



Integrate Access with Intrusion Systems:

- Cost efficient access solution, easily added & installed, affordable for even small to mid-size installs
- Seamless Integration with Gemini Control Panels GEMP3200, P9600, X255, GEMC; easily programmed with Napco Quickloader (single site programming and shared database)
- Supports HID & Gemini Prox Cards and Readers (both offered in money-saving kits)
- Optional PCD-Manager enduser software for corporate security or personnel departments, etc. Easy-to-use enduser Windows-based package for account management and self-maintenance provides limited enduser account control: Manage database of both alarm users and up to 1000 access control cardholders, logs, schedules, access groups, etc.(see right).
- Plug and play - GEM-ACCESS comes ready with its own enclosure, power supply (aux. for prox readers and mag locks) and battery backup. (GEM-ACMID)
- Fast card processing transaction speeds
- Easily expandable by-door with affordable GEM-2D Plug-in PCBs
- Supports HID or Gemini Prox (GEM-PX) Cards & Readers

Gemini Access

Ordering Information:

GEM-ACM1D Access Control Module for 1 door module in metal enclosure, w/ power supply, transformer and software enhancement upgrade EPROM for Gemini alarm panel.

GEM-2D 2nd Door plug-in PCB, for use in above.

GEM-1DKIT Economical GEM-PROX Kit Module in enclosure, w/ power supply, transformer, panel prom, GEM-PX prox reader with status LED indicators, 25 Gemini prox cards.

GEM-1DKITA HID reader kit, as above, with HID Reader and 25 HID 1326 prox cards

GEM-PX Gemini prox reader with access and alarm status indicators

GEM-PXC/50 50 Additional Gemini prox cards

GEM-H1326 HID prox reader

GEM-H1326C/100 100 Additional HID cards

PCD-MANAGER Optional on-site mgt. software, v.3.0 (below)

Gem-Access' PCD-Manager v3.0 enduser software for client security/personnel departments

Increases ID cardholder capacity to 1000

Napco's GEM-ACCESS Alarm/Access Control Integration System, supported by the GEMP3200, P9600 & X255 and GEMC Security Panels, enables you to offer your accounts optional Windows-based software to give their security and/or personnel departments limited control of their premises' alarm and access systems and authorized users, while safeguarding your system configurations, dealer codes, account ID's, central station number, etc. safely away from view. Plus, dealers can personalize the look of the account's software to represent their company, including options for uploading alarm company logos, website, tech support contact info., etc. with easy-to-use dealer customization utility built in.

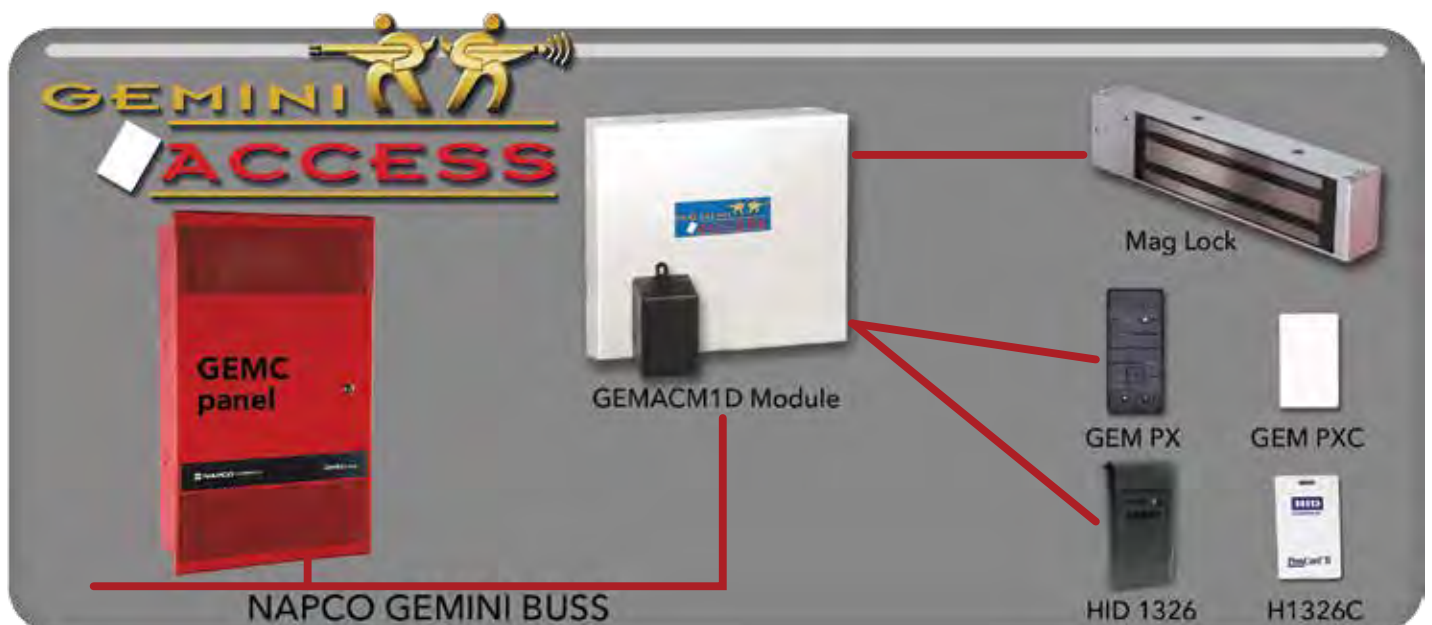

GEM-ACMID adds integrated access control to the burglar alarm functions of the GEMP3200, 9600, X255 and GEMC Gemini-Commercial Systems

Gemini Access: PCD-Manager (cont'd) & Universal Keyfob Kits

Easy account self-management interface for routine tasks, like adding alarm users/ID cards

- Easy personnel management for both alarm users (keypad user codes) & ID access cardholders
- Adding/editing/deleting personnel
- Importing text file names/data (including those from personnel files)
- **Now supports the Windows Quickloader "Extended Export Files", so you can import cards and personnel directly from the Windows Quickloader.**
- Viewing event logs
- Create and manage up to 195* access groups via intuitive drop-down menus and helpful screens (*see capacities chart, right)
- Assign users and/or access groups to easy-to-set schedules with pop-up calendar selections, drop-down menus, etc.
- Helpful Finalize Changes Summary screens summarize changes in a data-entry session for review before changes are made and downloaded.

- Comprehensive error-checking utility helps avoid errors and flags conflicts
- Report Print Manager - Alarm system users/info., cardholders, scheduled events & holidays & logs.
- Easy PCD-Manager link to panel via all standard Napco download modes (locally via serial COM port; remotely via telco line or remotely via TCP/IP network)

Gemini Access capacities, maximum by panel

Panel	Doors	Access Groups	Total Cards &/or Alarm Users	Expanded Cardholders (w/ PCD-Manager)
GemC	8	195	195	1000
X255	8	195	195	1000
P9600	8	96	96	1000
P3200	4	48	48	1000

Napco Universal Keyfob/Keyfob-Receiver Kits:



Bi-directional LCD keyfob compatible with all major alarm panel brands

2WAY-UNIVKFKIT

- Bidirectional keyfob with LCD status icon display and sounder.
- System Status is indicated on its LCD display with 8 intuitive icons (a lock, a house, a flame, etc.) plus corresponding audible beeps
- Universal panel compatibility with most major control panel brands, using bus or keyswitch input (including bus operation on NAPCO's Gemini & Magnum plus Honewell)
- Complete kit with dedicated 2-way Keyfob Receiver and one fob in **2WAY-UNIVKFKIT**; or add on up to 6 more fobs, sold separately **2WAY-UNIVKF**

Universal value keyfob... works with any alarm panel brand with keyswitch

UNIVKIT1

- Simple 2-button Arm/Disarm operation with LED indicator; optional panic
- Works with all control panel brands with keyswitch input
- Long range yet compact
- Complete kit with dedicated Keyfob Receiver (1-way) and one fob in **UNIVKIT1**; or add a second keyfob (max. 2), sold separately **UNIVKF1**

Gemini Wireless: Proven to outperform the competition



Napco's crystal-control Gemini wireless products have been proven by an independent testing laboratory to outperform competitive products, with long-range RF reliability, as much as 50% higher than other top brands.

Gemini Transmitters range from keyfobs and panic buttons, to recessed door and surface-mount window/door contacts, to wireless PIR, PIR/pet and dual sensors, and from wireless smokes and glass breaks to heat detectors. Simply put, Gemini's uncommon crystal-control precision and omnidirectional circuitry, ensures the wireless/hardwire systems you provide your customers will dependably deliver the security and trouble-free, peace-of-mind they deserve for many years to come.

Low profile wireless window/door transmitter

GEM-TRANSLP

- Ultra compact design, 2.5 x 1 x 0.4 (H x W x D inches)
- Tamper supervised
- Replaceable lithium PL2032 coin cell battery (supplied)
- 5-year battery life, typical
- Magnet and Internal reed switch
- External lead (24" mini connector pigtail) for wiring external devices (jumper-selectable)
- Magnet mounts with either supplied double-face tape or screws (screw tabs easily removable from mounting plate, at score)



Now in Brown, too, **GEM-TRANSLP-BRN**

Advanced performance Gemini RF receivers

GEM-RECV-XP8 8 Points
For Express, P801/800/
P400 panels, only

GEM-RECV-32 32 Points

GEM-RECV-96 96 Points

GEM-RECV-X255 255 Points

- Dual diversity antennas minimize nulls & enhance reliability
- Tamper- and RF-jamming supervision
- Separate programmable supervisory times by device type
- Audible fault-find mode in walk test
- Also, fixed English language keypad GEM-K4RF with built in 32 pt receiver (see keypads section).



GEM-TRANSLP virtually disappears even in slimline window frames

Recessed wireless window/door transmitter

GEM-RTRANS (not shown)

- For recessed use in both windows and doors
- Powerful wireless transmitter
- White housing, magnet & hole cover
- Field-replaceable 5 year battery. Long-life 3V type DL123A lithium battery supplied.

Wireless window/door transmitters

GEM-TRANS2 2-Points

- Soft white, compact, low profile
- Reversible mounting position for left or right handed operation
- Low battery clearly displayed at keypad by zone and transmitter number
- Both models include built-in reed switch, magnet, lithium battery, tamper and terminals

GEM-TRANS2BRN25

- Field-changeable brown housings for woodgrain installation (case of 25).



Wireless acoustic glass break detector

GEM-GB

- Superior-immunity to false alarms and excellent detection, even through blinds & light drapes.
- Pattern recognition technology - recognizes the actual pattern of glass breaking across the full audio band.
- 25' coverage radius with automatic test for easy installation
- Enduser hand clap sensor verification
- Includes lithium battery, tamper & mounting kit



Wireless Adaptive® dual microwave/PIR

GEM-DT

- Broad 40' x 40' range
- Exclusive Adaptive dual technology for superior false alarm resilience—even from animal/pet activity and optimized catch.
- Active self-test of both sensors
- 5 interchangeable lens patterns
- One button walk-test with auto shut-off
- 3 distinct transmissions for tamper alarm and self-test failure
- EMI/RFI protected with fully-shielded SMD circuitry
- Includes batteries, tamper and mounting screws



Wireless PIR & Pet PIR

GEM-PIR

- Broad 50' x 50' coverage
- 11 interchangeable lenses
- Signal selective processing
- Auto temperature compensation
- EMI/RFI protected with fully-shielded SMD circuitry.
- Battery-saver feature
- Includes lithium batteries and mounting screws

GEM-PIRPET

- As above with 40 lb. pet/animal immunity



Wireless photoelectric smoke detector

GEM-SMK

New & improved! Designer styling and longer battery life

- Long 5-year battery life, typ. (batteries included)
- Compact 5.2 inch diameter; attractive decorator white
- Built-in silence feature and test button
- Visual LED indicates alarm & standby
- Audible/visual indicator for low battery and need for detector cleaning
- Proven Gemini™ wireless crystal-controlled transmitter



Wireless heat detector

GEM-HEAT

- High-quality 135°F (57° C) fixed temperature detector with rate of rise
- Reliable, crystal-controlled wireless technology
- Long-life, replaceable lithium batteries



Wireless keyfob/emergency pendant transmitter

GEM-KEYF compact style

- 4-Button operation: 2 for On/Off of security system and 2 programmable for Aux. functions, e.g. panic, medical, relays or relay groups, instant or X-10 control
- Visual indicator for transmission or low battery
- Includes keyring, chain, replaceable battery, alternate icon key set for automation (lights)



Wireless waterproof panic

GEM-WP PANIC

- Waterproof personal panic button
- Worry-free peace of mind
- 1-button operation with tactile feedback click
- Extra-large, soft touch button for trouble-free use even by dexterity-impaired or arthritic hands



How to Build a Winning Gemini System.

1 Pick a panel



GEM-P816
GEM-P1632
GEM-P1664
GEM-P3200
GEM-P9600
GEM-X255

2 Pick a keypad



GEM-BIOREADER
OUTDOOR DIGITAL AND/OR
FINGERPRINT READER



GEM-RP1CAe2
INCLUDES 4 ZONE EXPANSION
MODULE BUILT-IN



GEM-K1CA
INCLUDES 4 ZONE EXPANSION
MODULE BUILT-IN



GEM-DK1CA
INCLUDES 4 ZONE EXPANSION
MODULE BUILT-IN



GEM-K1VPS
(GEM1664, 1632 only)



GEM-RP2ASe2



GEM-K2AS



GEM-RP3DGTL



GEM-K3DGTL



GEM-K4RF
WITH 32PT RF RECEIVER BUILT-IN FOR ALL
GEMINI EXPANDABLE PANELS

3 Pick a wireless device



GEM-WPPANIC
WATERPROOF PANIC



GEM-KEYF
KEYFOB



GEM-TRANSLP LOW
PROFILE WINDOW/DOOR -
LESS THAN 1/2" D



GEM-TRANS2
WINDOW/DOOR



GEM-PIR/
GEM-PIRPET
PASSIVE



GEM-DT
DUAL
TECHNOLOGY



GEM-RTRANS
RECESSED WINDOW/
DOOR



GEM-GB
ACOUSTIC GLASS
BREAK



GEM-SMK SMOKE



GEM-HEAT
DETECTOR



GEMINI PANELS

		GEM	P816	P1632	P1664	P3200	P9600	X255	P801
GEMINI KEYPADS	STAY & AWAY	K1CA/DK1CA	■	■	■	■	■	■	
	K1VPS		■						
	K2AS		■	■	■	■			
	K3DGTL/DK3DGTL		■	■	■	■	■		
	K4RF		■	■	■	■	■		
		K4	■	■	■	■	■		
CLASSIC		RP1CAe2	■	■	■	■	■	■	
		RP2ASe2	■	■	■	■	■		
		RP3DGTL	■	■	■	■	■		
		RP8LCD							■
		RP8/K800							■

2.1 Pick a smart phone/tablet interface (optional)



BRIDGE HOME CONTROLS APP
FOR ANY SMART PHONE OR DEVICE**



OPTIONAL iBR-ITAB
iBRIDGE TOUCHSCREEN TABLET



iREMOTEMOD/12
iREMOTE VIRTUAL KEYPAD MODULE
(**REQUIRES IPHONE/BLACKBERRY/ DROID SMARTPHONE OR COMPUTER)

(NOTE: iBridge Touchscreen may also be the primary keypad, See pg. 12).

2.2 Pick a panel accessory



GEMTEMP64
TEMPERATURE SENSOR
(FOR P1632/1664)



iBR-ZREMOTE
Z-WAVE DEVICE & SECURITY SYSTEM CONTROL MODULE (NOTE: iREMOTE-MOD ALSO AVAILABLE FOR REMOTE CONTROL W/O Z-WAVE)



GEM-EZM4/8
For P816, P1632 & P1664
ECONOMY 4 TO 8 ZONE EXPANSION MODULE

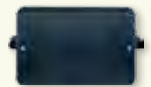

GEM-EZM8
FOR ALL GEMINI EXPANDABLE PANELS
* 8 ZONE EXPANSION MODULE



GEM-ACCESS
ADD-ON ACCESS CONTROL
(HID® OR GEM-PX)



RB3008
8 RELAY EXPANSION MODULE

4

Pick a wireless receiver
(Choose by # of wireless points)



32 PTS: GEM-RECV32
96 PTS: GEM-RECV96
255 PTS: GEM-RECV255

5 Choose communication alternatives (optional)



StarLink SLe-GSM & SLE-GSM-3/4G
UNIVERSAL PRIMARY OR BACKUP GSM RADIOS

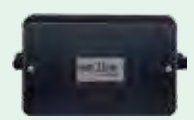

NetLink NL-MOD
BY-ZONE INTERNET REPORTING FOR GEMINI

NET-COMM
UNIVERSAL 5 CHANNEL REPORTING CODES ALL PANEL BRANDS



NetLink NL-RCV-RMPCUL
UL864/1610 RECEIVER FOR UL CENTRAL STATIONS

Napco Wired Motion Sensors: 20+ years of innovation inside



Patented Adaptive® slimline sensor and long-range version

C100STE & long-range model C100STLRE

- C-100STLRE 30' x 35' range
C-100STLRE 50' x 40' range
- Proven, patented adaptive technology continuously monitors the environment, counteracting false alarms and re-sensitizing to optimize intruder catch
- Active self-test supervision of both microwave & PIR channels
- Wide array of interchangeable lenses
- Secured cover; tamper-supervised

Napco patented Adaptive® Microwave/PIR Sensors virtually make all other motion sensors, dual technology or otherwise, obsolete. Once they're installed, they're like having a technician on-site, making all adjustments for you 24-hours a day.

These exclusive sensors are the only ones on the market that actively & continuously monitor their environment 24/7, counteracting false alarms and re-sensitizing themselves to continually optimize catch performance. In fact, some models will even notify you if they have been purposely or accidentally blocked or masked.

Ideal in all installations, despite harsh environmental conditions and/or pet/rodent activity, they provide the best protection available from both intruders and false alarms.

They pay for themselves with the first service call they prevent.

Commercial Adaptive sensors with mask/block supervision

M7100STE

- 40' x 40' range
- Active self-test supervision of both microwave & PIR channels
- Alarm memory with exit/entry delay
- Wrap-around shielded circuitry
- Wide array of interchangeable lenses
- 3' Dome of Protection™ for anti-masking & anti-blocking supervision
- Secured cover
- Tamper-supervised

M7300STE

- M7100STE features plus:
- 70' x 60' range
 - Tamper switch



Adaptive heavy-duty industrial-strength sensor

M9000STE

M7300STE features plus:

- Trio-range from 55' to 120'
- EZ aim, positive locking swivel bracket
- Concealed wiring channel
- Vandal-resistant industrial/ institutional strength housing
- 3' Dome of Protection anti-masking/anti-blocking supervision



Microwave/PIR Detectors continuously adjust to their environment, providing 100lb. pet/animal immunity and ultimate reliability & false alarm protection

C200AP with P.E.T.™

The best pet immunity for any size animal

- P.E.T.™, Profile enhanced targeting circuitry provides up to 100lb. (45.36Kg) pet immunity
- 40' x 40' maximum broad range
- Compromise-free intruder-catch and false alarm protection - ideal when the pet leaves the room, too. Dynamic adaptive technology literally adjusts to its surroundings minute-by-minute, once the pet vacates the detector again elevates its sensitivity, mode by mode
- Smarter Systems™ panel & sensor integration input
- Superior RFI/EMI lightning protection with wrap-around shielded SMD circuitry
- Twin-Tee fluorescent light interference filter
- Self-test
- 2 Field-changeable lenses supplied
- Range control & auto-temp compensation

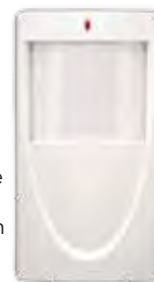

Feature-packed advanced passive infrared sensors

Microprocessor PIR with 65lb pet immunity & built-in room-temp alert

PIR1680PT

- 45' x 45' range
- 65lb pet/animal immunity
- Room-temp alert - temperature monitoring provides auto-alert at 40°F - 90°F
- Look-down/creep zone
- D.C.I.D. Technology- detect & compare imaging diagnostics for advanced false and true alarm detection
- Active self test mode
- Exceptional RFI-/EMI/lightning shielding of key components
- Lens bank available, including long range, barrier, and specialty ranges
- Wall or corner mountable
- Tamper supervised
- Form A relay

PIR1680

- Standard model as above, but with 20lb. pet/animal immunity



Advanced 70' PIR

PIR1710

- 70' x 60' Broad range coverage perfect for both residential and commercial
- Features look-down/creep zone
- SSP™ (Signal Selective Processing) for the easiest and most stable of installations
- Auto temp compensation
- Advanced, EZ-Aim fresnel lenses and lens bank for optimum detection performance
- Wall or corner mountable
- Excellent EMI-/RMI-/lightning protection with resilient SMD circuitry
- Tamper supervised
- Form A relay

Economical PIR sensor with look-down

PIR1510

- 30' x 30' broad range coverage
- Attractive, super-compact size
- SSP™ (Signal Selective Processing) for the easiest and most stable installations
- Advanced, EZ-Aim fresnel lenses and lens bank for optimum detection performance
- Long-range, barrier and specialty lenses are available to suit all coverage needs
- Wall or corner mountable, with horizontal and vertical adjust
- EMI-/RMI-/lightning protection with resilient SMD circuitry
- Form A relay
- PIR1500 version also available, as above, without look-down/creep zone.



The pet-immune PIR with Quick-Catch that profiles false alarm sources and virtually installs itself

For decades, NAPCO's innovative technology has produced sensors with superior false alarm discrimination. Today NAPCO is a leader in smart PIR technology, P.E.T. immunity, and décor-enhancing design.

IQ PROFILER™

- 50lb. pet immunity (22.7Kg) & superior false alarm discrimination with unique dual focal lenses.
- Installation in a snap with patented Quick-Mount and Quick-Wire terminals
- Maximum range: 50' x 50'
- New & improved quick-catch mode
- Décor white bi-optic contour case and dual focal lenses provide exceptional distance profiling
- Far field lens allows for detection of large objects and ignores small targets nearby
- Near field lens allows for discrimination of small targets nearby
- Shielded high-performance aspheric lenses plus look-down/creep zone
- Sensor chamber prevents insect, draft, and dust interference.
- 20V/m RF-shielded circuitry

IQ VISION Advanced PIR with "IQ Look" and now all-white styling

- 40' x 40' range; 30lb. pet immunity
- Features look-down/creep zone
- SSP™ (Signal Selective Processing) for the easiest and most stable of installations
- Auto temp compensation
- Advanced, EZ-Aim fresnel lenses and lens bank for optimum detection performance
- Excellent EMI-/RMI-/lightning protection with resilient SMD circuitry
- Tamper supervised
- Form A relay (Form C option)
- Long-range, barrier and specialty lenses are available to suit all coverage needs
- Wall or corner mountable, with horizontal and vertical adjust

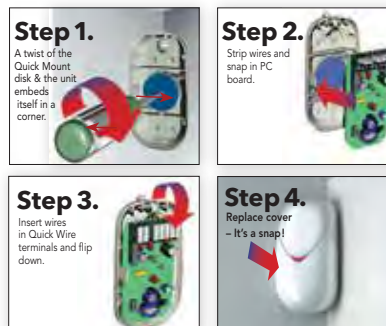

iBridge Connected Home Configurations & Ordering:

Are you using Z-WAVE?

NOTE:

- Remote Services Compatible.
- Ability to connect/control Security, Climate, Lighting, & Video externally outside of home/business.
- Requires iBridgeonline.com account for Remote Services.
- Local access available as well, which doesn't require iBridgeonline account.

NOTE:

- Without IBR-ZREMOTE, no Remote Services are available.
- You can use iSeeVideo for local or remote viewing externally, outside of home/business.
- Requires iBridgeonline or iSeeVideo account for Remote Services.
- For Remote Services, use IBR-ZREMOTE, iRemote or iSeeVideo.

YES

NO

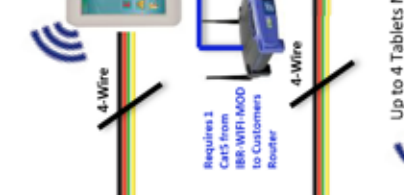

Part #
IBR-ZREMOTE
(All in One, Remote Services)

Part #
IBR-ITAB-HW
(Hardwired Tablet For use as Keypad Only)

- Thermostats
- Locks
- Switch Receptacles
- Dimmer Modules
- Appliance Switch Module

- Wall Switches
- Lamp Modules
- Remote Controls
- Ceiling Fan Modules
- Wall Scene Controllers

- Requires 2 Cat5 from IBR-ZREMOTE to ISEE-WAP or Customers Router

- Compatible with:
- 3200/9600/X255 V20 or greater.
- 816/1632/1664 V30 or greater or 32PIN Socket V10.
- GEM-P816
- GEM-P1632
- GEM-P1664
- GEM-P3200
- GEM-P9600
- GEM-X255

- Requires 1 Cat5 from IBR-WIFI-MOD to Customers Router

- Up to 4 Tablets Max. Wireless Tablet

- Smart Devices, NO PC
- *Local Only* - APP

Part #
IBR-ITAB-KIT
(IBR-ZREMOTE Required)

Part #
IBR-ITAB
(IBR-WIFI-MOD Required)

Part #
IBR-WIFI-MOD
(For Wireless Tablets & iSeeVideo)

Part #
ISEE-WAP

FAQs

How do I connect the IBR-ZREMOTE?
The IBR-ZREMOTE connects to the 4-wire Keypad Bus and require (2) Cat5 Internet cable connections to either the ISEE-WAP or customer supplied wireless router.

How do I connect the IBR-WIFI-MOD?
The IBR-WIFI-MOD connects to the 4-wire Keypad Bus and requires (1) Cat5 connection to the customers supplied router.

How do I connect the ISEE-WAP?
The ISEE-WAP gets connected to the customers router through (1) Cat5 Cable.

iBridge Ordering Information:
Sold as a Kit or Individually

IBR-ZREMOTE – ALL-IN-ONE Bus Mounted module for remote control, Upload/Download of security system, IP Reporting, PLUS control of Z-Wave devices (lights, locks, thermostats, etc.).

IBR-ITAB-KIT – iBridge Touchscreen Tablet with mounting frame/charging station plus WAP Wireless Access Point (ISEE-WAP).

IBR-ITAB – iBridge Touchscreen Tablet with mounting frame and charging station.

ISEE-WAP – Wireless Access Point.

IBR-ITABSTAND – Angled tabletop stand/docking station for use with IBR-ITAB Touchscreen.

iBridge Ordering Information:
Sold Individually

IBR-ITAB-HW – Hardwired iBridge Touchscreen Tablet for permanent mounting and more conventional hardware installation.

IBR-WIFI-MOD – Wireless Panel interface, communicates between internet, Gemini Panel and IBR-ITAB Wi-Fi Touchscreen Tablet, when NO remote services are used (NOTE: For remote services use IBR-ZREMOTE).

IBR-ITAB – iBridge Touchscreen Tablet with mounting frame and charging station.

IBR-ITABSTAND – Angled tabletop stand/docking station for use with IBR-ITAB Touchscreen.

iSeeVideo Cameras connect Wirelessly through ISEE-WAP or IBR-WIFI-MOD
LOCALLY or REMOTELY

	ANALOG/ IP CONVERTER	ISEE-SCHGW/12
	FIXED	ISVWLCAM
	PAN/TILT	ISVWLCAMPT
	OUTDOOR	ISVWLOCAM
	INDOOR	ISVWLDCAM

To Activate Remote Services visit www.NapcoComNet.com



COMMERCIAL & GOVERNMENT SOLUTIONS



NAPCO



Continental **Access**



ALARM LOCK



MARKSUSA

Integrated Intrusion • Fire • Video • Access • Locking

- **Innovative integrated enterprise class solutions** - reliable, high-quality security, life-safety, video, access and/or locking technologies integrated in one scalable interoperable platform called **Napco Fusion™**.
- **Comprehensive Expert Support** - for endusers, architects and engineers, security consultants and commercial integrators
- **Professional Tools, Training & Communications** - A growing list of the latest design support tools, CSI specifications, CAD diagrams and configuration aids are available on our website. Go to <http://goo.gl/cbTdU> An expert online support forum ensures continuous news and information is disseminated. Accredited training is provided in the field and in live and archived webinar modules online.
- **Strong Security Heritage** - Napco Security Technologies, Inc. (NASDAQ: NSSC) has been solely dedicated to developing and manufacturing innovative professional security solutions since its founding in 1969.
- **Industry-Leading Brands** - Napco Commercial™ Gemini™, Continental CardAccess®, Alarm Lock Trilogy®, Networx™ and Marks-USA™
- **Commitment to Quality** - ISO9001:2000 Certified and subscribing to a rigorous quality management system, Napco products are precision-manufactured to meet or exceed industry specs.
- **Built to Last** - Napco stands behind its products with among the longest warranties in the industry and even legacy systems are often field upgradable for lowest maintenance costs. Today, millions of people, businesses, institutions & residences around the world are protected by Napco products.

Napco Fusion™ Platform is a unique total integrated security solution for intrusion, fire, video, access & locking.



FUSION™

A Total Integrated Solution:

INTRUSION • FIRE • VIDEO • ACCESS • LOCKING



Napco Security Technologies' new Napco Fusion™ total security solution, built on a heritage in professional security, developing innovative, reliable security technology, including some of the industry's best-known brands: Napco Gemini, Continental CardAccess®, Alarm Lock Trilogy® and Marks USA. Today, together in one flexible customizable platform called Napco Fusion™, all Napco's synergistic technologies combine in one sophisticated, simplified **total integrated security solution**, providing seamless, near interoperability of intrusion and fire protection, video, access control & locking.

- Scalable, modular enterprise-class platform for intrusion, fire, video, access and locking
- 2 to thousands of doors, unlimited users, at one or many global sites
- Lowest acquisition and maintenance costs
- No annual software licensing fees
- Wired, wireless or hybrid system, for lowest installation cost in any type of building
- 921Kbps high-speed access control processing & 1/2-second door open times
- Multi-card, PIV, biometric, & keypad support
- Complete DVR/NVR and camera control, on-demand and video archiving video
- Napco Commercial™ Intrusion, Fire and UL Commercial Wireless Alarm Integration
- Integration with Trilogy® Networkx™ Wireless Networked pushbutton/HID® Prox access locks (ethernet or 802.11 global comm.)
- Integrated realtime event linking, mapping, scheduling & logging of alarms, video, access control & locks
- Threat level & visitor management
- Secure TCP/IP reporting option; AES encryption up to 256bit
- Remote web client, standard
- Software runs as a Service; LDAP support

- Intrusion
- Fire
- Video
- Interactive Online Services
- Access control



www.napcosecurity.com/newproducts.html
 1-800-645-9445
 salesinfo@napcosecurity.com
 333 Bayview Ave., Amityville, NY 11701

- Standalone electronic access locks, PIN code & prox ID card
- Wireless advanced networked locks, Ethernet or 802.11 global communications
- Alarmed exit devices & door alarms



www.alarmlock.com
 1-800-ALA-LOCK
 salesinfo@alarmlock.com
 345 Bayview Ave., Amityville, NY 11701

Enterprise class access & integrated security solutions:

- Alarm Lock & Napco Alarms Integration
- DVR/NVR, video & alarm integration
- Visitor & threat level management
- LDAP Support & Software Runs as a Service
- Remote web client
- FIPS/TWIC/CAC support
- 1 to 16-Door Controllers for millions of cardholders & super-speeds over 921Kbps



www.continentalaccess.com
 631-842-9400
 salesinfo@cicaccess.com
 355 Bayview Ave., Amityville, NY 11701

- Architectural locking hardware & custom locksets
- Lifesafety Ligature-Resistant locks
- Classroom Intruder Lock-Down Locksets
- Electrified locksets
- Ornamental iron & woven wire gate locks
- High security cylinders



www.marksusa.com
 1-800-526-0233
 salesinfo@marksusa.com
 365 Bayview Ave., Amityville, NY 11701



About Napco:



Napco Security Technologies, Inc. has a long heritage solely dedicated to developing innovative technology and reliable security solutions for the professional security community, including popular Gemini intrusion and fire systems, StarLink Universal Wireless GSM Radios, Napco Commercial 24V Addressable/Wireless Systems; Firewolf Commercial Fire Panels & Devices; iBridge Connected Home Remote Services & iSee Video™ Remote Video. Today, Napco technologies protect millions of people, businesses, schools, hospitals & residences around the world. Napco products are reliable, high quality, built to last, and proudly backed by the industry's longest warranty.



1-800-645-9445 • www.napcosecurity.com

NAPCO • ALARM LOCK • CONTINENTAL ACCESS • MARKS USA
333 Bayview Avenue • Amityville, New York, U.S.A. 11701 • Fax: 631-789-9292
International ++ 1 631 842 9400 NASDAQ: NSSC A402K

Napco Commercial, Firewolf, Gemini, iBridge, iSeeVideo, iRemote, StarLink, NetLink, Napco Express, Quickloader, Adaptive, Trilogy/Networx, CardAccess, Napco Fusion, LocDown & LiveSaver are trademarks of NAPCO. iPhone, iPad, Droid, Blackberry, Z-Wave, Microsoft / Windows, HID, & iClass are trademarks of their respective companies. Pats. & Pats. pending. Some preliminary specifications are subject to change. NAPCO Security Technologies, Inc. © NAPCO, 2013