



Quick Setup Guide

Superterm Controller (CICP1800) / Turbo Superterm Controller (CICP1800T)

CardAccess 3000 Software

For Your Convenience

Please contact Continental Access Technical Support (phone 631-842-9400) if you still have questions after reading this **Quick Setup Guide**.

Please visit the Continental Access website for all documentation including Service manuals, installation manuals and FAQ's. Go to www.cicaccess.com, click **support**, and then click **Hardware/Software Document Library**.

Installing / Upgrading CardAccess 3000 Software

1. Verify your computer has **FULL LOCAL ADMINISTRATOR RIGHTS**. The computer should be running Windows XP Pro SP3 32 bit, Windows 2003 Server 32 bit, Windows 7 Professional 32 bit or Windows 2008 Server 32 bit.
2. To install the software, insert the CardAccess 3000 CD into the CD Rom drive. The installation should start automatically. If the installation does not auto-start, click **Start, Run**, and then type **D:\launch.exe** and click **OK**.
Note: "D:" is the CD-Rom drive letter. If your CD-Rom drive letter is different, you must change it to the drive letter used in your system.
3. After the installation starts, click "**Install CardAccess 3000**". A few components will install prior to the "**Setup Type**" screen displaying. On the "**Setup Type**" screen, select the type of installation you are performing. If you are installing a CardAccess 3000 host, select "**Install CardAccess Server with Database**". If you are installing a CardAccess 3000 workstation, select "**Install CardAccess Workstation**". All CardAccess 3000 systems must have one CardAccess host. Workstations are optional. On a new system, you should install the CardAccess 3000 server/host first.
4. **Note:** If you are performing an upgrade from a previous version of CardAccess 3000, refer to the appropriate upgrade documents on the Continental website.
5. When the installation or upgrade is complete, you will be prompted to restart your computer. Click "**Yes, I want to restart my computer**".
6. Launch the CardAccess 3000 software by clicking the **CA3000** launcher icon. The CardAccess 3000 default Username is "Admin", and the Password is "q".

Note: After installing or upgrading the CardAccess 3000 software, you must download new firmware to your controllers.

Things to Remember:

1. The **password** for the CardAccess utility (database utility) and the Sqlexplorer utility is "**pr1532**".
2. Verify your computer meets the **recommended computer specs** and you are using a supported operating system. Refer to the Continental website for the computer specifications.
3. Verify you have full **LOCAL ADMINISTRATOR RIGHTS** on the computer.
4. Verify you have the **CA3000 Installation CD**.
5. Verify you have the correct **security key** or **software license** for your version of software. Security keys and software licenses are unique for each version.
6. If you are using **network** communications to your panel, verify you have downloaded the "**DeviceInstaller**" utility from Lantronix. The "DeviceInstaller" utility is used to program the network settings into the Lantronix device.
7. If you are using Serial Communications, and your PC has no physical comport, verify you have a **USB-to-Serial Cable**.
8. Refer to the Continental Website for FAQ's. Go to www.cicaccess.com, click **support**, and then click **Hardware/Software Document Library**.

Programming the CardAccess 3000 Software

1. After a new CardAccess 3000 installation is performed, you are required to program a few items to get a basic system functioning. The following steps will assist you with programming the required items:
 - Click "**Configuration/Comports**". Click **Edit** and configure your comports for cable or network. If you are using network communications, it is recommended to use Comport 5 or higher.
 - Click "**Configuration/Panels**". Click **New** and configure a panel. Select the correct Panel type, Com Port and Panel Address. The Com Port setting is the comport configured in the previous step.
 - Click "**Administration/Schedules**". Click "**New**". Enter a "Description" (ex. 24 x 7). Click in the "**Start Day**" box. A "24 x 7" schedule fills in automatically (Start Day = MON, End Day = HOL, Start Time = 12:00 AM and End Time = 12:00 AM). Click **Save**.
 - Click "**Configuration/Readers**". Click "**New**". Select the correct panel, which this reader is attached to. Click **Save**.
 - Click "**Access/Access Groups**". Click "**New**". Enter a "Description" (ex. "All Access"). Click "+" next to Panels/Readers at the bottom of the screen. Configure a Time Schedule for each reader. Select the "24 x 7" schedule previously created.
 - Click the "**Personnel**" icon. Click "**New**". Type your "Badge Number", "First Name" and "Last Name". Click the "**Access Groups**" tab. Click the drop down box "**Access Group 1**". Select the "**All Access**" access group previously created.
2. After the basic programming is complete, verify the CardAccess 3000 host is communicating with the panel. Go to "**Configuration/Panels**", and perform a "**Full Download**" to the panel. After the download is complete, verify the badge is working correctly. A "**Badge Valid**" alert should display when the badge is presented to the reader.

Communication Connections

Superterm/Turbo Superterm to Host computer

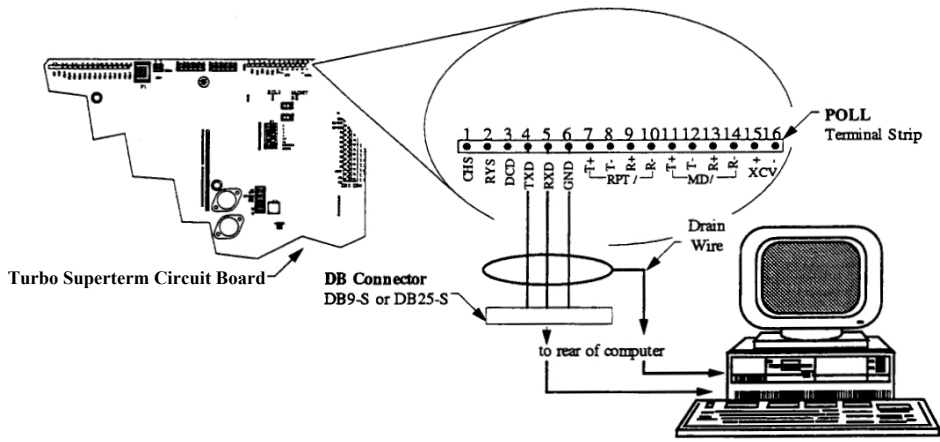

Superterm/Turbo Superterm RS-232 to RS-422 Repeat Network

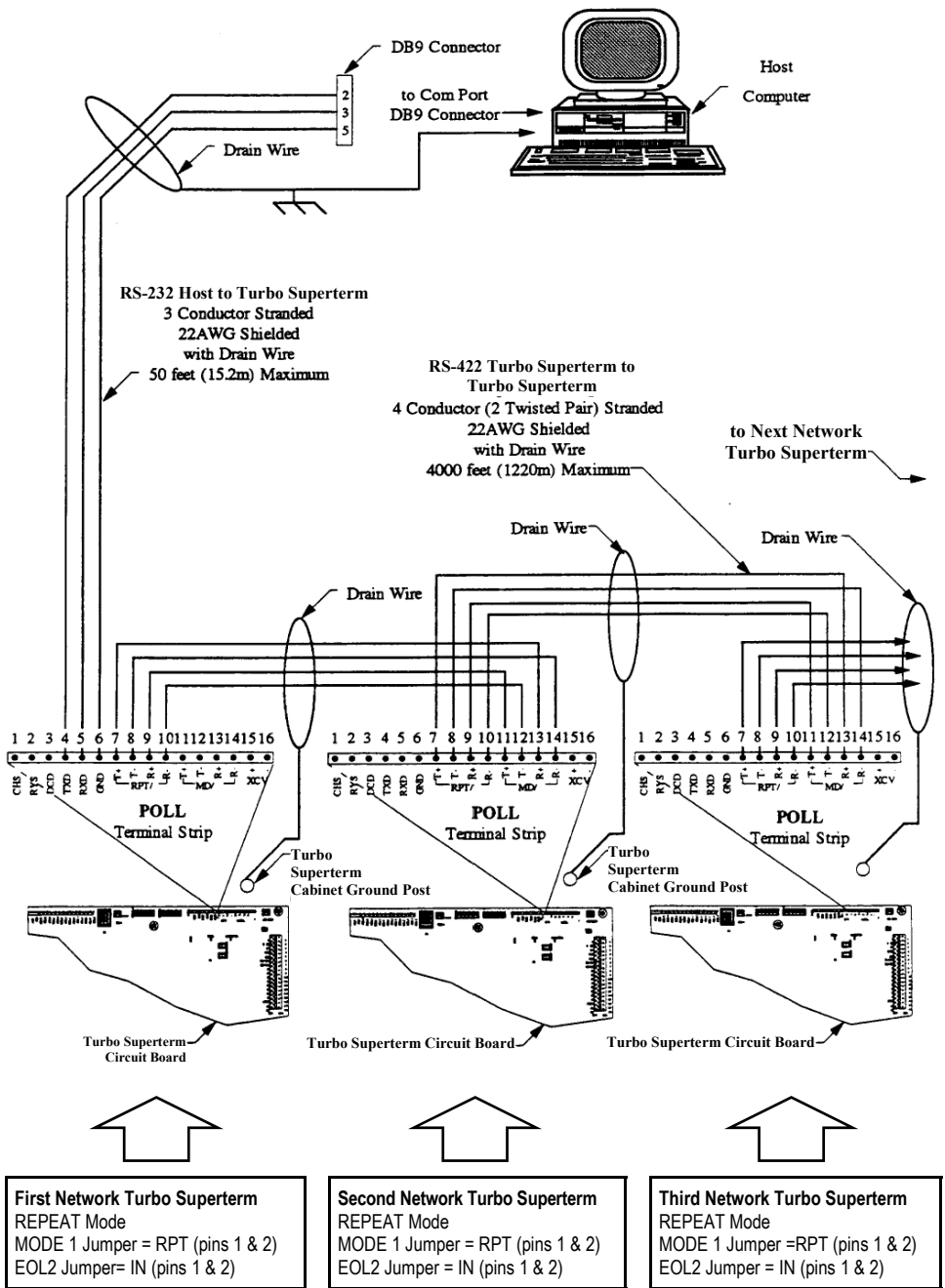

Superterm/Turbo Superterm Jumpers REPEAT Mode

MD/RPT Jumper (J7)

Set the jumper to contact the center post (pin 2) and the left-hand post (pin 1).



Jumper installed on left and center pins

MODE1

EOL2 Jumper

Set the EOL2 jumper to the TERMINATED position contacting both pins (1 and 2).



Jumper Installed (Terminated)

EOL2

Address Switches

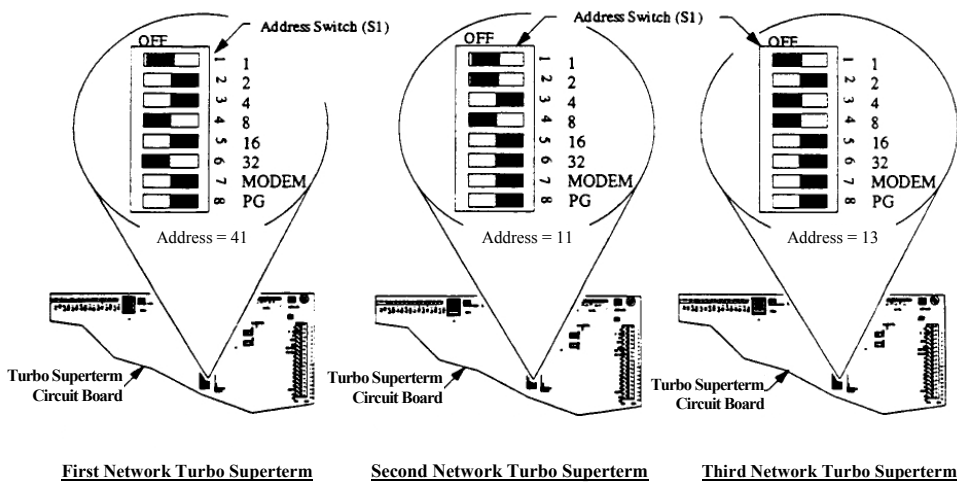

Door Sensor

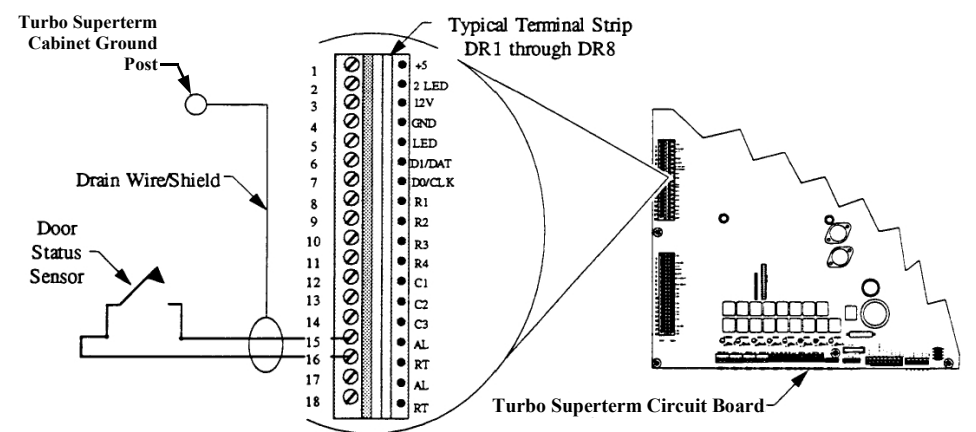

Reader Wiring

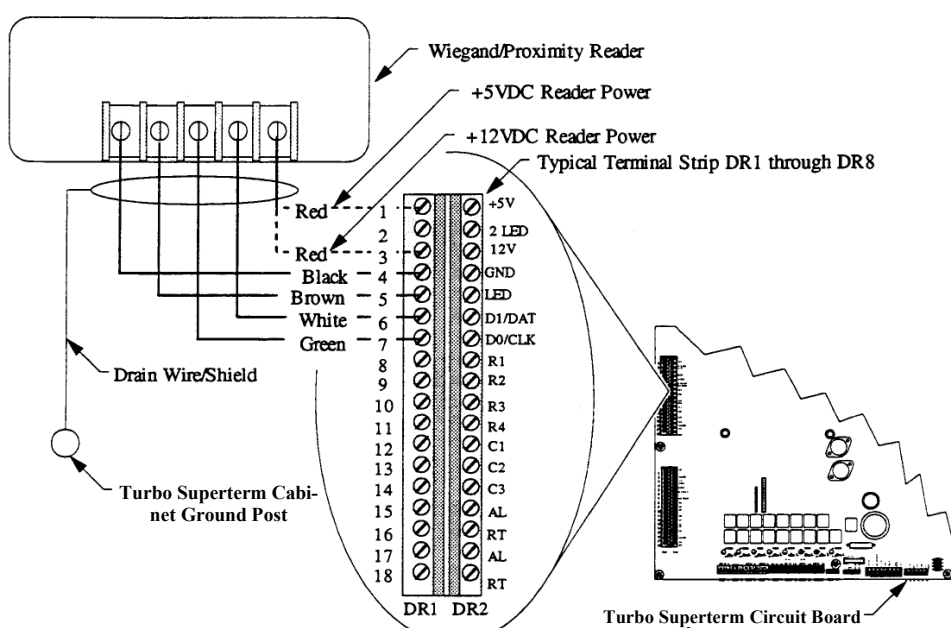

REX Wiring

